

Installation Guide

V945D Network Dome Cameras



XX292-00-01



Vicon Industries Inc. does not warrant that the functions contained in this equipment will meet your requirements or that the operation will be entirely error free or perform precisely as described in the documentation. This system has not been designed to be used in life-critical situations and must not be used for this purpose.

Document Number: 8009-8292-00-01

Product specifications subject to change without notice.

Issued: 6/19 Copyright © 2019 Vicon Industries Inc. All rights reserved

Vicon Industries Inc.
Tel: 631-952-2288 Fax: 631-951-2288
Toll Free: 800-645-9116
24-Hour Technical Support: 800-34-VICON
(800-348-4266) UK: 44/(0) 1489-566300
www.vicon-security.com

Notice

Copyright Statement

This manual may not be reproduced in any form or by any means to create any derivative such as translation, transformation, or adaptation without the prior written permission of Vicon Industries.

Vicon Industries reserves the right to change this manual and the specifications without prior notice. The most recent product specifications and user documentation for all Vicon Industries products are available on our web site www.vicon-security.com.

Trademarks

Vicon and its logo are registered trademarks of Vicon Industries.

All other trademarks that may appear belong to their respective proprietors.

FCC Warning

The V945D Series Dome Cameras comply with the FCC rules.

Operation is subject to the following two conditions:

- This device will not cause harmful interference.
- This device must accept any interference received, including interference that may cause undesired operations.

The V945D Series HD IR IP Dome Camera have been tested and found to comply with the limits for a Class A digital device, pursuant to the FCC rules. With these rules and regulations being obeyed to maintain the good working condition of device, the operation is not supposed to be affected by the external interruptions under certain circumstances. This device is electromagnetic, so all the installation and application processing along the device has to follow strictly to the manual or it may hamper telecommunications around. Meanwhile, there is no guarantee that interference will not occur in a certain particular installation situation.

Read this manual carefully before installation. This manual should be saved for future use.

Important Safety Instructions and Warnings:

- Electronic devices must be kept away from water, fire or high magnetic radiation.
- Clean with a dry cloth.
- Provide adequate ventilation.
- Unplug the power supply when the device is not to be used for an extended period of time.
- Only use components and parts recommended by manufacturer.
- Position power source and related wires to assure to be kept away from ground and entrance.
- Refer to qualified personnel for all service matters.
- Save product packaging to ensure availability of proper shipping containers for future transportation.



Indicate that the uninsulated components within the product may carry a voltage harmful to humans.



Indicate operations that should be conducted in strict compliance with instructions and guidelines contained in this manual.

Warning: To avoid risk of fire and electric shock, keep the product away from rain and moisture!

CONTENTS

Chapter I System Introduction	1
1.1 Product Description.....	1
1.2 Product Model.....	2
1.3 Product Features.....	2
1.4 System Requirement	3
1.5 Specifications.....	3
1.6 Notes.....	6
Chapter II Installation.....	7
2.1 Installation Precautions	7
2.2 Dimensions	7
2.3 Installation of Surface-Mounted Camera	7
Chapter III IE Browser Settings	12
3.1 Equipment Connection.....	12
3.2 Software Installation	12
Chapter IV Basic Function Operation.....	15
4.1 Live View.....	15
4.2 System	19
4.2.1 System Information.....	19
4.2.2 Time Settings	19
4.2.3 Advanced Settings.....	21
4.3 Network Settings.....	24
4.3.1 Network Settings.....	25
4.3.2 FTP Settings.....	26
4.3.3 SMTP Settings	27
4.3.4 HTTPS Settings	28
4.3.5 802.1X Settings.....	28
4.3.6 QoS Settings	28
4.3.7 IGMP Settings.....	29
4.3.8 SIP Settings.....	30

4.3.9 DDNS Settings.....	31
4.3.10 UPnP Settings	32
4.3.11 NAS Settings.....	33
4.3.12 RTSP.....	34
4.3.13 IP Filter	35
4.3.14 Monitor Connect	36
4.4 Camera Settings	38
4.4.1 Basic Settings	38
4.4.2 Exposure Settings	39
4.4.3 Effect Settings.....	40
4.4.4 White Balance.....	42
4.4.5 Focus Settings.....	43
4.4.6 IR Set.....	45
4.4.7 Reset	45
4.5 Video and Audio Settings	46
4.5.1 Video Settings	46
4.5.2 OSD.....	48
4.5.3 Motion Detection	51
4.5.4 Privacy Mask	52
4.5.5 ROI.....	53
4.5.6 Storage Path.....	54
4.5.7 Audio Settings.....	54
4.6 Video Contents Analysis Functions	55
4.6.1 Camera Tampering.....	55
4.6.2 Line Cross Detection.....	57
4.6.3 Intrusion Detection	59
4.7 Alarm Settings.....	60
4.8 Storage Management.....	63
4.8.1 Record Settings.....	63
4.8.2 Replay.....	64

4.9 User Settings	65
4.10 System Log	68
Appendix I Questions & Solutions.....	70

CHAPTER I SYSTEM INTRODUCTION

1.1 Product Description

The V945D Series Dome Camera adopts progressive scan CMOS sensor with an internal HD motorized zoom lens. The camera has an internal Smart IR technology that provides 98 ft/30m IR distance. The IR LEDs output power can be adjusted automatically according to the brightness of the scene so that the IR LEDs do not work at full capacity. The power consumption of the complete unit is greatly lowered and the service life is lengthened.

V945D Series cameras can support up to 2592×1944@30fps video output. The cameras use H.265/H.264/M-JPEG encoding, providing output with excellent definition and color reproduction, more detailed and accurate information and the accuracy of smart analysis that can, effectively, be guaranteed.

V945D Series cameras boast smart functions, including camera tampering, to detect if the camera/lens has been moved, blocked, low/high brightness or defocused; intrusion detection, providing protection for key areas; and line cross detection, providing border protection, which are important features for many enterprises. These cameras can be widely used in sites that demand high definition image quality in low lighting environments, such as ordinary buildings, supermarkets, hotels, shops, parks, schools, factories, warehouses, underground parking lots, etc.

The compact design makes it easy to install and provides 3-axis adjustment, for easy adjustment of the monitoring angle.

1.2 Product Model

This manual is for the following models:

V945D-W310MIR HD Megapixel IR IP Dome Camera, WDR, Intelligence, 5.0MP, 1/1.8"CMOS, day/night, H.265/H.264/M-JPEG, with audio/alarm, 3.6~10mm motorized zoom lens, 98ft/30m IR distance, IP66, PoE/12VDC/24VAC

1.3 Product Features

- 1/1.8" Progressive scan CMOS sensor
- IR-Cut Removable (ICR) Filter for Day/Night switching
- 98ft/30m IR distance
- Uses Smart-IR technology; auto-adjusts IR LED power according to ambient illumination
- Supports digital WDR
- Smart functions, such as camera tampering, line cross, and intrusion detection
- Built-in motorized zoom lens, supporting assistant focusing
- H.265/ H.264/M-JPEG video encoding, three streams
- Maximum resolution supports 2592×1944@30fps
- Bi-directional audio, G.711a/G.711u/AAC
- Supports corridor mode
- Local PC recording
- Supports TF card (also referred to as SD card) storage/NAS storage
- Supports alarm recording and event recording (including broken network)
- Supports alarm snapshot and event snapshot
- Supports multiple alarm trigger methods such as I/O input, motion detection, smart detecting, SD card out, network link down, heart beat lost, etc.; supports flexible alarm association settings like I/O output, emails, FTP picture uploading, audio, TF card recording and alarm information push
- Up to eight ROI (Region of Interest) areas

- Supports motion detection, 4 areas configurable
- Supports privacy mask, 4 privacy areas configurable
- Supports live access and parameter setting via Web Server from multiple users
- Compatible with Vicon Valerus VMS software
- Standard SDK provided for easy integration with other video surveillance software
- ONVIF Profile S and Profile G compliant
- Surface mount; mounting accessories available
- 3-axis adjustment
- IP66 rating
- Rugged design (IK10)
- Supports PoE/12VDC/24VAC power supply
- Provides analog video output

1.4 System Requirement

Configuration of the computer to display image and control the camera:

CPU: Intel Pentium 4, 2.4 GHz or above

RAM: 512MB or greater

Network Port: 100M Ethernet port

Operating System: Microsoft Windows 10, Windows 7, Windows XP

IE browser version: Microsoft Internet Explorer 8.0 or above

1.5 Specifications

Model numbers	V945D-W310MIR
Image Sensor	1/1.8" CMOS
Lens Configuration	Motorized zoom lens, F1.5, f=3.6~10mm
Lens Mount	Φ14
IR Lamp Wave Length	850nm
Night Vision Distance	30m

Camera Angle Adjustment	X (Panning): 0°~360°; Y (Tilting): 0°~72°; Z (Rotating): 0°~360°
Day/Night Switching	ICR
Sensitivity	Color mode: 0.1Lux@F1.5, AGC ON B/W mode: 0.02Lux@F1.5, AGC ON 0 lux (IR ON)
Exposure	Scene, Manual, Shutter
Shutter	Auto/Manual (adjustment range 1/1s~1/32000s)
AGC	Auto/Manual adjustable, max. 64X
White Balance	Auto/Manual/Outdoor
WDR	100dB
Video Adjustment	Brightness, contrast, saturation, hue, sharpness
Noise Reduction	3D
Defog	Available
EIS	Available
Corridor Mode	Available
Image Mirror	Horizontal/Vertical mirror
Video Compression	H.265/H.264/M-JPEG
Max. Encoding Capacity	2592×1944@30ps+720×480@30fps+ M-JPEG640×480@5fps
Optional Resolution	Major stream(H.265/H.264): 2592×1944/2560×1920/2048×1536/1920×1080/ 1280×960/1280×720; Minor stream(H.265/H.264): 720×480/704×480/640×480/352×240/320×240; Third stream (H.264/M-JPEG): 720×480/640×480/352×240/320×240
Output Code Rate	Variable; Constant: major stream: 256Kbps~1000Kbps; minor stream: 256Kbps~2000Kbps
Audio	Compression: G.711a, G.711u, AAC Sampling rate: 8KHz, 16KHz, 32K, 44.1K, 48K optional Port: 1 linear input, 1 linear output

Smart Functions	Abnormal Video detection, line cross detection, and intrusion detection
Network Delay	≤250ms
Motion Detection	Supports up to 4 motion detecting areas
Privacy Mask	Up to 4 masks
ROI	Up to 8 regions
Internal Storage	Supports a Micro SD/SDHC/SDXC card (128G)
Mirroring Storage	Supports uploading of recordings saved on TF card during network disconnection to the VMS or NVR after network recovery
Local PC Recording	Available
Remote Network Upgrade	Available
Password Protection	Available
Network Port	One RJ45 10/100M self-adaptive Ethernet port
Analog Video Output	Available, BNC connector
Alarm	2 alarm inputs, 1 on-off output
Network Protocols	IPv4, IPv6, TCP, UDP, IGMP, DHCP, FTP, SNMP (V3), SMTP, NTP, RTP, RTSP, RTCP, HTTP, HTTPS, TSL, SSL, 802.1X, QoS, PPPoE, DNS, DDNS, ARP, ICMP, UPnP, ONVIF
IP Address Filter	Available
Power Supply	PoE (IEEE 802.3af)/12VDC/24VAC
Power	<9W
Protection Design	Lighting protection (network port and power supply connector): protection differential mode 2KV, common mode 4KV surge; Anti-static (all ports): contact protection 6KV static
Operating Temperature	-40°F ~ 140°F (-40°C ~ 60°C)
Storage Temperature	-4°F ~ 140°F (-20°C ~ 60°C)
Operating Humidity	0%~90% RH (non-condensing)
Unit Dimensions (H×Ø)	4.02"×5.43" (102.1 mm×137.8 mm)
Box Dimensions (L×W×H)	8.03"×6.34"×8.11" (204 mm×161 mm×206 mm)
Unit Weight	1.98 lb (0.9 kg)
Shipping Weight	2.54 lb (1.15 kg)

1.6 Notes

1. After login, first perform network settings. The gateway IP address should be set as that of the connected network camera.
2. The IP address cannot conflict with that of other devices; if there are conflicts, the camera cannot be viewed.
3. If the camera utilizes a PoE power supply, connect equipment strictly according to the parameters of the Power Supply Switcher. Additionally, a practical test of maximum network cable length for the Power Supply Switcher must be performed, to avoid camera failure caused by insufficient power supplied to the Power Supply Switcher or to avoid the harm to the Switcher.

These units should only be installed by a qualified technician using approved materials in conformance with federal, state, and local codes. Read these instructions thoroughly before beginning an installation. Always refer to Vicon's website to assure you have the most up-to-date manual, www.vicon-security.com.

The camera is supplied with an accessory kit that includes mounting hardware (screws, anchors and grommets), an RJ-45 connector protective cover, a power connector (2-pin screw terminal), replacement/spare locking screws (screws that secure the camera module in its cradle), a BNC cable connector that allows connection of spot monitor and an Allen tool to loosen the screws.

CHAPTER II INSTALLATION

2.1 Installation Precautions

- Do not drop the camera or subject it to harsh movement.
- Do not point the camera lens directly toward the sun or other strong light.
- Do not install the camera in environments with temperature beyond the acceptable range (-40°F to 140°F/-40°C to 60°C), or with high humidity, direct rainfall, frequent vibrations and shocks.

2.2 Dimensions

Unit: inch (mm)

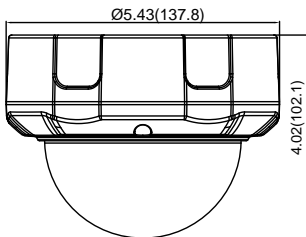

Figure 2-1 Surface-mounted Dome Camera

2.3 Installation of Surface-Mounted Camera

Select a location that is clear of obstacles and can support the weight of the unit. Exercise maximum caution when installing the unit to the wall or ceiling the unit falling can result in injuries and accidents. As a failsafe against falling, attach the unit by chain, wire cable or other safety restraint to an appropriate anchor point. Cabling should be routed to the installation location.

Step 1: Prepare the mounting holes

Prepare four mounting holes in the specified location, as shown in the figure below.

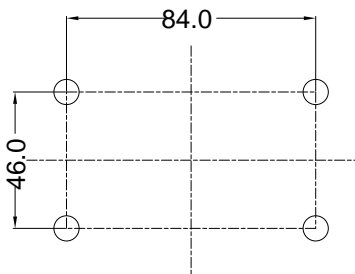

Figure 2-2 Location of Mounting Holes (unit: mm)

Note: Make sure there is a proper position for a cable hole. The cables are connected to a pigtail cable assembly on the camera.

Step 2: Install the camera

Loosen the three screws on the clear dome assembly with the Allen tool provided to remove the clear bubble. Note that there is a bag of desiccant inserted in the camera assembly; do NOT remove this.

Secure the camera to the wall/ceiling with four supplied M4x25 umbrella-type self-tapping screws, anchors and grommets (or fastening hardware appropriate for the mounting surface).

Step 3: Adjust the camera angle

Loosen the locking screws, adjust the camera angle and direction to the desired position and then tighten the screws.

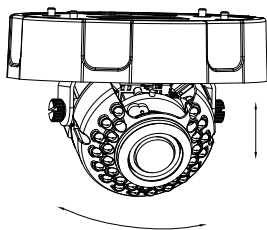

Re-install the clear dome assembly to the camera and secure with the screws.

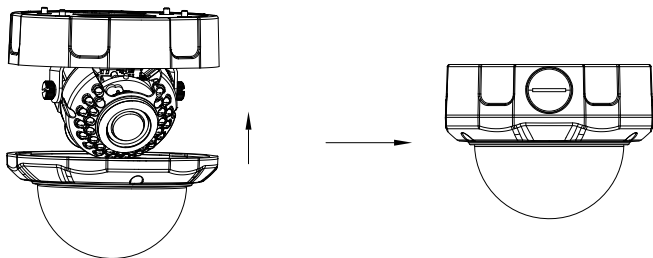

- Refer to the figure below for connection and utilization of alarm input and output.

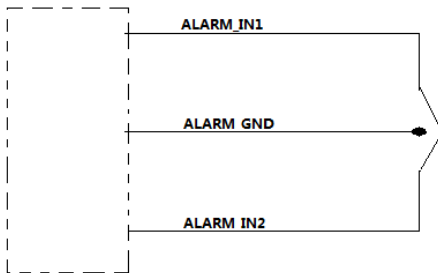

alarm in connect

If ALARM IN connect ALARM_GND, it is equal to input 0 electrical level .

If ALARM IN is open or connect high electrical level, it is equal to 1 electrical level .

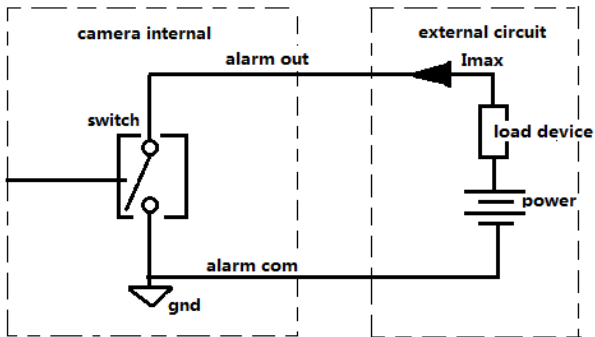

alarm out connect

note: 1. $I_{max} \leq 500\text{MA}$
 2. $\text{power} \leq 24\text{V}$

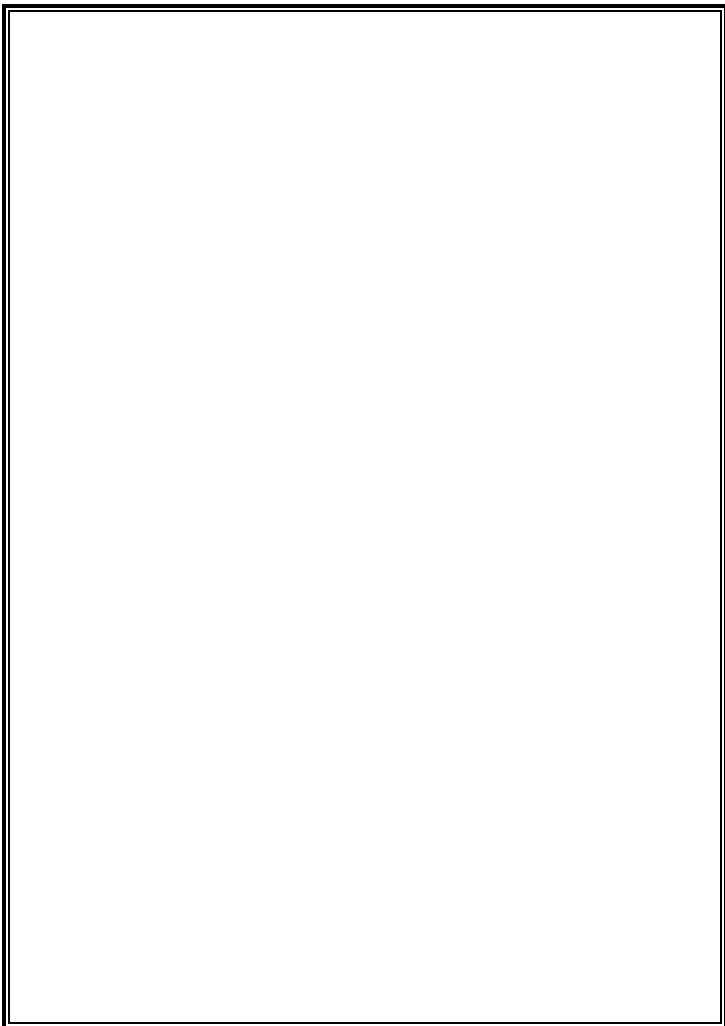

CHAPTER III IE BROWSER SETTINGS

When viewing the video, the user needs to adjust the Internet Explorer (IE) browser and set proper system functions based on the following instructions:

- Support IE browser version: Internet Explorer 8.0 or above, however, IE 10 or above is required for full functionality, including the file upgrade function.
- Make sure the system has installed the player control component.

3.1 Equipment Connection

V945D series camera can be connected directly to a computer or a network.

Note: Check that the connection is correct and secure before power-on.

3.2 Software Installation

The installation procedure of the V945D series camera software is as follows:

(1) Login

Open the IE browser and enter IP address. Enter user name and password in the pop-up login interface. For first time users, the default admin login is ADMIN (case sensitive; password: 1234). For increased security, it is recommended to change the password.

(2) Install control

There are two ways to install control.

Method 1:

The prompt message below will display in Live view window after a successful login. Click the link to run, or store, the .exe file; then run the file.

Attention:Please allow running VICON add-ins.If it does not load automatically, please [click here](#) to install manually,and refresh the page after that.

Figure 3-1

If the installation fails, check whether video can be viewed through another IE window or page. Close the video or the IE window immediately. If it succeeds, click refresh; live video can be viewed.

Method 2:

The prompt message below will display in the page after a successful login. Right click “Add-on Disabled” and select “Run Add-on”.

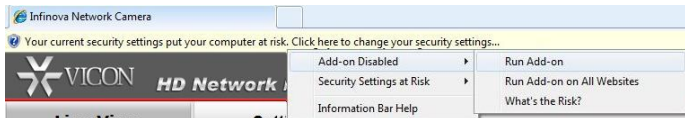

Figure 3-2

A security warning will pop up to remind the user to install video player control (Web_VideoPlayer). Click “Install.”

The video player control is installed, live video can be viewed. If a reboot prompt pops up, cancel reboot. Then close all the IE windows and install video player control again. The live video will display as below:

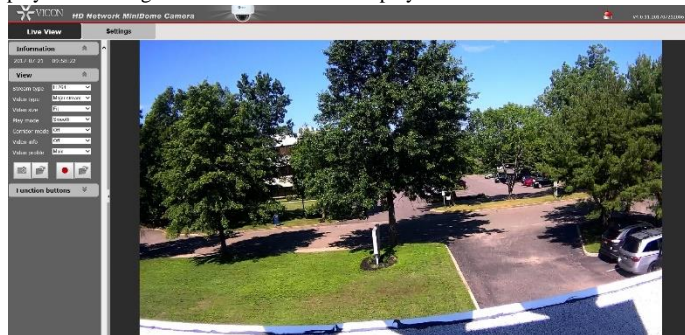

Figure 3-4

 **Note:**

If the video player control installation fails, the live video won't display. In that case, the IE security level should be changed.

1. Click "Tool" in the menu bar and then select "Internet Options" from the drop-down menu.
2. Select "Security" in the pop-up Internet options.
3. Click the "Internet" icon and then click "Custom Level."
4. In the options of "Download unsigned ActiveX controls" select "Enable" or "Prompt." Click OK.
5. Select "Privacy" option, clear (deselect) "Block pop-ups." Click Apply and OK. Reopen the screen and install control as per the prompt. The live video will display.

CHAPTER IV BASIC FUNCTION OPERATION

This chapter will explain the settings and operation that the admin can perform for the V945D Series.

4.1 Live View

After the server is powered on for about 90 seconds, open the IE browser, and then enter IP address in the address field.

The user login interface is displayed as shown in figure below.

A screenshot of a user login dialog box. It has a light beige background and a blue border. At the top left, it says "User name:" followed by a text input field containing a blue icon of a person and a dropdown arrow. Below that, it says "Password:" followed by an empty text input field. Under the password field, there is a checkbox labeled "Remember my password". At the bottom, there are two buttons: "OK" and "Cancel".

Figure 4-1 User Login

Note that the dome camera defaults to using DHCP. If DHCP is enabled and the product cannot be accessed, run the Discovery Tool utility to search for and allocate an IP address for the camera. The Discovery Tool (IPCCConfig.exe) can be found on Vicon's website, www.vicon-security.com, on the Software Downloads page for Vicon cameras.

When running the software and logging in for the first time, use the default admin username and password. The default User is ADMIN (uppercase, case sensitive) and the password is 1234.

It is recommended to modify the password of the admin user to ensure the safety and security of the system.

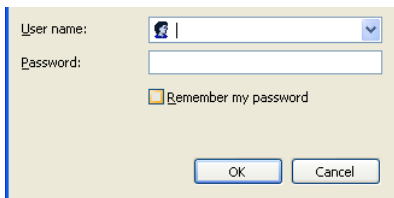
When the login is successful, the following interface will display:

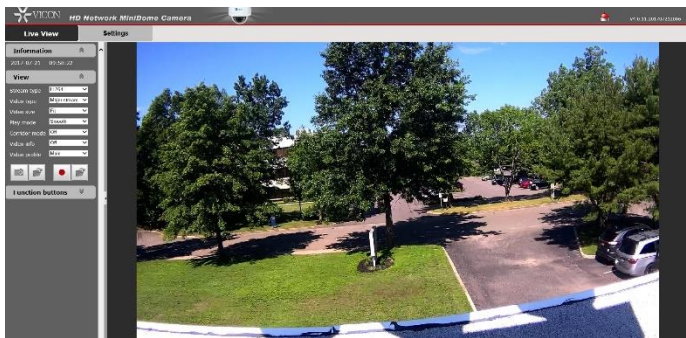

Figure 4-2 Live View

The V945D Dome Camera supports H.265, H.264 and M-JPEG video compression formats. After the login, users will enter the Live view interface displaying the major stream at H.264 format.

Stream Type: Users can select H.265 or H.264 from the Stream type dropdown list.

Video Type: Users can select major stream, minor stream or M-JPEG from the Video type dropdown list. In the H.265/H.264 major or minor stream type, users can record and take a snapshot.

Video Size: Users can select a video scale from the dropdown (Fit, Full, 1x, 1/2x, 1/4x). Fit allows the video to be the size of the window without changing the aspect ratio; Full spreads over the entire window and the aspect ratio changes with the size of the window; 1X maintains the full resolution of the video and 1/2x and 1/4x reduces the resolution by 1/2 or 1/4, respectively.

Play Mode: Users can select Live or Smooth; Smooth will produce an image with less noise and better quality.

Corridor Mode: When the mode is enabled, the horizontal angle narrows while the vertical angle stretches, as shown in Figure 4-3.



Note: 90°clockwise rotation is needed for angle adjustment when using corridor mode.





Figure 4-3 Corridor Mode

Video Info: Show or hide video information (Bite rate and frame rate). If the video type or stream type is changed, video info is set to off automatically.





Video Profile: For H.264 stream type, the video profile can be set to High, Main or Base.





Snapshot: Click the button  to take a snapshot. Click the button  to access the saving path of the snapshot; default: C:\VideoPlayerAX\Picture.

Local recording: V945D Series supports local recording. Click the recording button  to start recording; the button changes to ; click the button to stop recording. During local recording, “REC” appears on the video screen. Click the button  to enter the recording storage path; default: C:\VideoPlayerAX\ Video.

Users can set the snapshot and recording storage path in the Audio & Video settings interface.

Function buttons:

  Indicate audio input/output are disabled. Click the buttons to enable audio input/output; the buttons will be shown as  .

  Indicate that the motion detection and privacy mask functions are disabled. Click the buttons to enable them; the buttons will be shown as  .



Indicates that the Video Content Analysis functions are disabled. Click the button to enable them; the button will be shown as

Note: The motion detection and privacy mask settings can only be set in the Live view settings interface when they are enabled in the Audio & Video Settings. Refer to Sections 4.5.3 or 4.5.4 for details.

Note: The login web page language should be set to the same as that of PC's operating system.

Click the option tab “Settings” to enter the system Settings interface.

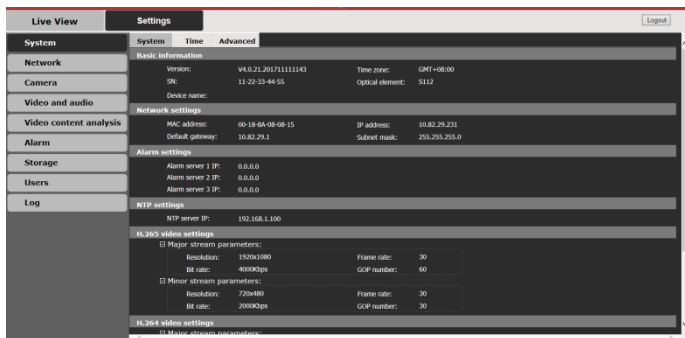

Figure 4-4 Settings Interface

Using the navigation menu on the left, admin can perform the following operations: Basic Information view, Time settings and Advanced settings, Network settings, Camera settings (including Basic Set, Exposure Set, Effect Set, White Balance, Focus, IR Set, Reset), Video and Audio settings, Video Contents Analysis, Alarm settings, Storage settings, Users settings (Add/Delete User, Change Password), Log, etc.

 **Note:** The following instructions are for the admin use.

4.2 System

Click “System” in the left navigation bar to display the following three option tabs: System, Time and Advanced, as shown in Figure 4-4.

4.2.1 System Information

The initial interface of System settings displays related system information, such as Basic system information, Network settings, Alarm settings, NTP settings, H.265/H.264/MJPEG video settings, etc.

4.2.2 Time Settings

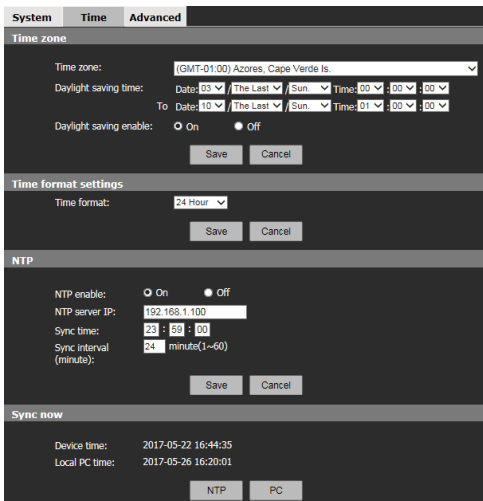

System **Time** **Advanced**

Time zone

Time zone: (GMT-01:00) Azores, Cape Verde Is.

Daylight saving time: Date: 03 / The Last / Sun. Time: 00 : 00 : 00

To Date: 10 / The Last / Sun. Time: 01 : 00 : 00

Daylight saving enable: On Off

Save Cancel

Time format settings

Time format: 24 Hour

Save Cancel

NTP

NTP enable: On Off

NTP server IP: 192.168.1.100

Sync time: 23 : 59 : 00

Sync interval (minute): 24 minute(1~60)

Save Cancel

Sync now

Device time: 2017-05-22 16:44:35

Local PC time: 2017-05-26 16:20:01

NTP PC

Figure 4-5 Time Settings

Time Zone Settings

Time Zone: Select the desired time zone from the dropdown list. There are 33

time zones available to select from.

If Daylight Saving Time is used in the location, users can enable the Daylight saving option by selecting the On radio button and enter the correct dates for the daylight saving time period.

When settings are completed, click “Save.”

Time format settings

Select the time format from 24 hour or 12 hour. The date format can be set as MMDDYYYY, DDMMYYYY or YYYYMMDD in the OSD menu.

When settings are completed, click “Save.”

NTP Settings

To set the NTP, check the On radio button; select Off if this will not be used. Set NTP server’s IP address and synchronization time and interval parameters.

When settings are completed, click “Save.”

Sync now

There are two sync modes: local PC sync and NTP sync.

PC sync means the device time is consistent with that of local PC. In the NTP sync mode, the system will check time with the NTP server automatically to adjust time.

Be sure to save settings before leaving the interface or cancel any changes made.

4.2.3 Advanced Settings

System **Time** **Advanced** []

File import

[] **Browse...** (Please choose upgrade file)

Submit

Factory settings

Press the button to reset all the parameters to the factory default settings

Keep current IP unchanged:

Reset

Reboot

Press the button to reboot the system, the window will reload after it

Reboot

Figure 4-6 “Advanced” Settings

Software Update

Free software updates are provided for V945D Series cameras on the Vicon website on the Software Downloads page and can be downloaded to a PC or other media device.

Follow the steps below to update software:

Under File import, click “Browse” button on the interface and the file selection dialog box will pop up.



Figure 4-7

Select update file and press “Open” button. The selected update file will be displayed in the Software Update box. Click “Submit” button to update software; the following information will appear:

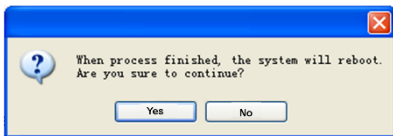

Figure 4-8

Click “Yes” button and run the program to finish the update.

The response time depends on the program type; it may take a long time for some programs. Do not power off during the update process; power-off will cause the update to fail or damage the original program or disrupt update again. After a successful update, a reboot of the system is required. There is a time prompt in the web page during reboot. After reboot, a new web page will open to run new program.

Note: This is only available for the admin.

Factory Settings

V945D Series cameras provide an online reset function, which greatly facilitates reset adjustment.

Select “Keep current IP unchanged,” click “Reset” button and the system will pop up the message to confirm factory reset:

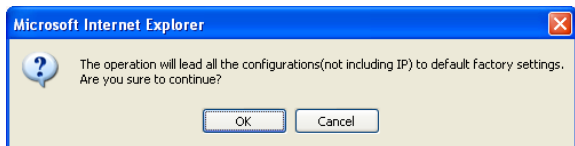

Figure 4-9

Click “OK;” all the parameters (excluding IP address) will be reset to the factory default settings.

If “Keep current IP unchanged” is unselected, the IP address will be reset to DHCP mode.

There is time prompt in the web page during reset. After reset, a new web page will open.

Note:

1. To avoid any errors, the online reset function operation should be performed under qualified personnel’s guidance.
2. Do not power off during reset or the reset will fail.

Online Reboot

Click “Reboot” button; the dialog box “This operation will take 90 seconds, are you sure to continue? ” will pop up. Click “OK” and the system will restart. There is a time prompt in the web page during reboot. After reboot, a new web page will open.

Note: This is only available for the admin.

4.3 Network Settings

Click “Network” in the left navigation bar; the following interface will display:

Network	FTP	SMTP	HTTPS	802.1X	QoS	IGMP	SIP	DDNS	UPnP
NAS	RTSP	IP filter	Monitor						

Network	
IP mode:	IPv4
DHCP:	<input checked="" type="radio"/> On <input type="radio"/> Off
IP address:	10.82.19.120
Subnet mask:	255.255.255.0
Default gateway:	10.82.19.1
Primary DNS server:	10.82.1.4
Secondary DNS server:	10.82.1.6
<input type="button" value="Save"/> <input type="button" value="Cancel"/>	

Port	
Host name:	localhost
Ornif port:	8000
Http port:	80
Https port:	443
<input type="button" value="Save"/> <input type="button" value="Cancel"/>	

PPPOE	
State:	<input type="radio"/> On <input type="radio"/> Off
User name:	
Password:	
IP address:	
<input type="button" value="Save"/> <input type="button" value="Cancel"/>	

Telnet	
Telnet Service :	<input type="radio"/> ON <input type="radio"/> OFF
<input type="button" value="Apply"/>	

SNMP	
Heartbeat server IP:	0.0.0.0
Heartbeat interval:	1 sec.(1~300)
<input type="button" value="Save"/> <input type="button" value="Cancel"/>	

Figure 4-10 Network Settings

There are 14 option tabs for settings: Network, FTP, SMTP, HTTPS, 802.1X, QoS, IGMP, SIP, DDNS, UPnP, NAS, RTSP, IP Filter and Monitor.

4.3.1 Network Settings

IP mode: There is support for both IPv4 and IPv6 modes. The configuration of Network parameters will differ depending on the mode selected.

Network

IP mode:	IPv4
DHCP:	<input checked="" type="radio"/> On <input type="radio"/> Off
IP address:	10.82.19.119
Subnet mask:	255.255.255.0
Default gateway:	10.82.19.1
Primary DNS server:	192.168.0.254
Secondary DNS server:	10.82.1.6

Save Cancel

Figure 4-11 Network Settings

Users can enable (On) or disable (Off) DHCP. When it is disabled, users can set unit IP address, Subnet mask, Gateway and DNS server IP address manually.

Note: The system indicator quickly flickers for 5 seconds after the network settings are completed successfully.

Enter Host name and Port settings for Onvif, Http and Https.

Users can enable/disable PPPoE in this interface. If enabled, users can set the user name and password.

Telnet service can be turned On or Off as required.

In SNMP settings, the cameras support a heartbeat function. Set and save the Heartbeat server IP address and Heartbeat interval; the heartbeat package will be sent to the server or client, which greatly facilitates the server or client to know about the camera's network status.

Be sure to save settings before leaving the interface or cancel any changes

made.

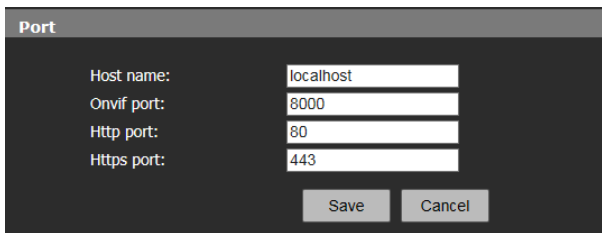

Host name:	localhost
Onvif port:	8000
Http port:	80
Https port:	443

Save Cancel

Figure 4-12 Port Settings

Onvif port default value is 8000, it is for onvif connection.

Http port default value is 80, it is for web connection.

Https port default value is 443, it is for web https connection.

If need change these ports, must change port value and click save.

Note: The port settings of the software platform must be consistent with the port settings of the camera. If inconsistent, it needs to be modified.

4.3.2 FTP Settings

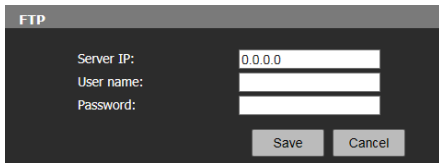

Server IP:	0.0.0.0
User name:	
Password:	

Save Cancel

Figure 4-13 FTP Settings

V945D cameras support the function of alarm associated FTP image upload (alarm triggered image snapshot). Configure server IP, user name and password in the FTP settings. Then activate the alarm associated FTP uploading function in the alarm setting interface to activate the FTP image uploading function upon alarms.

4.3.3 SMTP Settings

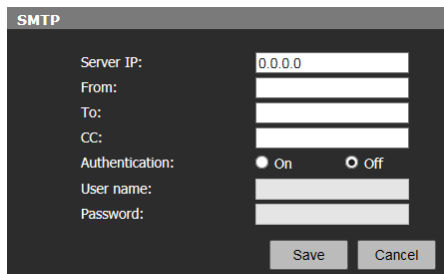

Figure 4-14 SMTP Settings

The cameras support the function of alarm associated email sending. The email server and receiver information are set in the SMTP setting interface.

- **Server IP:** Set mail server address.
- **From:** Set sender's mail address.
- **To:** Mail address of recipient.
- **CC:** Mail address of the recipient of a copy.
- **Authentication:** Enable or disable authentication function. This function should be set according to authentication requirements of mail server.
- **User name:** Sender's name; this can be set according user's needs.
- **Password:** Set sender's password.

Note: There is no limit for Sender's name and password settings.

After setting, click "Save" for settings to take effect.

If user selects "Mail" in "Alarm Settings" interface, system will send emails according to SMTP settings.

4.3.4 HTTPS Settings



The screenshot shows a dark-themed interface with a title bar that reads "CA certificate import". Below the title bar, there is a label "CA certificate:" followed by a text input field. To the right of the input field is a "Browse..." button, and further to the right is a "Submit" button.

Figure 4-15 HTTPS Settings

V945D camera supports HTTPS protocol. Import the CA certificate in the interface.

4.3.5 802.1X Settings

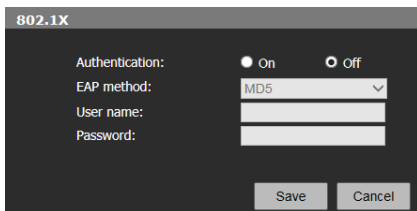

The screenshot shows a dark-themed interface with a title bar that reads "802.1X". Below the title bar, there are four settings: "Authentication:" with radio buttons for "On" (selected) and "Off"; "EAP method:" with a dropdown menu showing "MD5"; "User name:" with a text input field; and "Password:" with a text input field. At the bottom right, there are "Save" and "Cancel" buttons.

Figure 4-16 802.1X Settings

V945D Series supports 802.1X protocol. Enable 802.1X authentication when needed. Then, select an EAP method and enter the user name and password. Be sure to save settings before leaving the interface or cancel any changes made.

4.3.6 QoS Settings

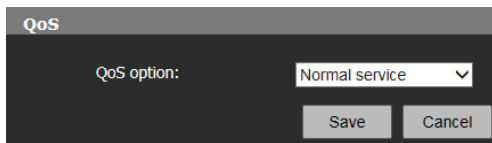

The screenshot shows a dark-themed interface with a title bar that reads "QoS". Below the title bar, there is a label "QoS option:" followed by a dropdown menu showing "Normal service". At the bottom right, there are "Save" and "Cancel" buttons.

Figure 4-17 QoS Settings

Select the network service quality in the QoS setting interface. There are 4 network QoS modes:

- (1) Normal Service
- (2) Max Reliability
- (3) Max Throughput
- (4) Min Delay

Recommended/Default: Normal Service.

Be sure to save settings before leaving the interface or cancel any changes made.

4.3.7 IGMP Settings

IGMP

Stream channel: Major Stream

State: On Off

MultiCast IP address: 224.0.1.88

RTP port: 8888

Auto multiCast: On Off

Stream type: TS stream ES stream

Save Cancel

Figure 4-18 IGMP Settings

V945D cameras support multicast function. In the IGMP interface, users can select the stream type and set the state, multicast IP address and RTP port. For auto multicast, users can set the status as On or Off and set the stream type as TS stream or ES stream.

4.3.8 SIP Settings

SIP server	
SIP server IP:	192.168.1.100
Port:	5060
Server ID:	
Device ID:	
Alarm ID:	
Register Interval:	1900
Heart beat Interval:	60
Auth UserName:	[none]
UserName:	[none]
Password:	••••••••
<input type="button" value="Save"/> <input type="button" value="Cancel"/>	

Position Information	
Position name:	
Longitude:	0.00
Latitude:	0.00
<input type="button" value="Save"/> <input type="button" value="Cancel"/>	

Figure 4-19 SIP Settings

SIP Server: Configure SIP server for device:

SIP Server IP: IP address of SIP server

Port: Port number of SIP server

Server ID: ID of SIP server

Device ID: Device ID used for registration with SIP server

Alarm ID: ID registered for device alarm

Register Interval: Interval for re-registration of device in seconds

Heart Beat Interval: Interval to send heartbeat information by the device in seconds

After configuration is completed, click “Save” and the device sends a registration request to the server.

Position Information: Mounting information or instruction for device.

Longitude: Longitude of mounting position, precisely to two decimal places

Latitude: Latitude of mounting position, precisely to two decimal places

Be sure to save settings before leaving the interface or cancel any changes made.

4.3.9 DDNS Settings

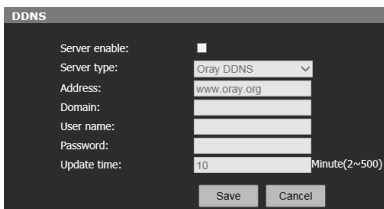

Figure 4-20 DDNS Settings

Dynamic Domain Name System (DDNS) can enable continuous synchronization of the host name and dynamic IP address. Users only need to input the dynamic domain name to connect to a network camera instead of memorizing the dynamic IP address.

To employ this method, a PC with a static IP address needs to be available and, additionally, a dynamic domain name server must be running at the PC.

Operation: Select the Server enable option and then select the DDNS type. Enter the IP address of the DDNS server into the address bar, configure Domain, User name, Password and Update time. Then Save the settings. Open the IE browser, enter the domain name to access the web search page of the device.

Be sure to save settings before leaving the interface or cancel any changes made.

4.3.10 UPnP Settings

A mapping relation between a private network and an external network is built via UPnP protocol. Select UPnP option to enter the configuration page. The mapping list added will appear on the page.

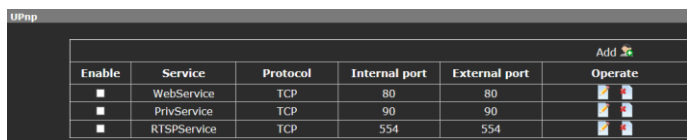

The screenshot shows a window titled "UPnP" with a table of service mappings. The table has columns for Enable, Service, Protocol, Internal port, External port, and Operate. There are three rows of data. An "Add" button with a plus icon is in the top right corner.









Enable	Service	Protocol	Internal port	External port	Operate
<input type="checkbox"/>	WebService	TCP	80	80	 
<input type="checkbox"/>	PrivService	TCP	90	90	 
<input type="checkbox"/>	RTSPService	TCP	554	554	 

Figure 4-21 UPnP Settings

In the “Operate” column, click  to delete and  to edit user information. Click Add button to add a mapping.

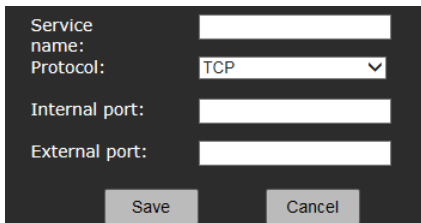

The screenshot shows a configuration form with the following fields:

- Service name:
- Protocol: (dropdown menu)
- Internal port:
- External port:

At the bottom, there are two buttons: "Save" and "Cancel".

Figure 4-22

Be sure to save settings before leaving the interface or cancel any changes made.

4.3.11 NAS Settings

NAS	RTSP	IP filter	Monitor
Server configuration			
NFS server IP:	<input type="text" value="192.168.1.100"/>		
NFS server path:	<input type="text" value="/home/nfs"/>		
CIFS shared name:	<input type="text"/>		
Video held days:	<input type="text" value="0"/>		
Stream type:	<input type="text" value="Major"/>		
When disk is full:	<input type="radio"/> Cover <input type="radio"/> Uncover		
Recording control:	<input type="radio"/> Start <input type="radio"/> Stop		
		<input type="button" value="Save"/>	<input type="button" value="Cancel"/>
Storage information			
Storage state:	No		
Total space:	0 MB		
Used space:	0 MB		
Available space:	0 MB		
Used percent:	0%		
Media server			
Rtsp IP address:	<input type="text"/>		
Rtsp path:	<input type="text"/>		
		<input type="button" value="Save"/>	<input type="button" value="Cancel"/>

Figure 4-23

The camera supports NAS (Network Attached Storage) function that allows you to save the recorded videos on the network server.

Server Configuration: Set the NFS server IP, NFS server path, CIFS shared name, video held days, stream type, what to do when disk is full and recording control.

Storage Information: View the storage state, total space, used space, available space and used percent.

Media Server: Set the Rtsp IP address and Rtsp path. Be sure to save settings

before leaving the interface or cancel any changes made.

4.3.12 RTSP



Allowed anonymity:	On	▼
Login type:	Digest	▼
RTP packet max size	1	▼ MTU

Save Cancel

Figure 4-24 RTSP Setting

Allowed anonymity: If “On” is selected, there will be no need for the client to have user authentication when a video by RTSP is requested.

Login Type: Select **Login Type** from the drop-down menu. You can choose **Basic** (send general text password through network to verify user password) or **Digest** (system uses encryption information to verify user password). You need to set **Login Type** when **Allowed anonymity** is “On.”

RTP Packet max size: Select the maximum size of standard data packet with “byte” as its unit.

Be sure to save settings before leaving the interface or cancel any changes made.

You can access the RTSP stream through the following links when turn on Allowed anonymity.

For major stream: `rtsp://IP/ch1/stream1` ;

For minor stream: `rtsp://IP/ch1/stream2`;

For third stream: `rtsp://IP/ch1/stream3`;

You can access the RTSP stream through the following links when turn off Allowed anonymity.

For major stream: `rtsp://ADMIN:password@IP/ch1/stream1` ;

For minor stream: rtsp://ADMIN:password@IP/ch1/stream2;

For third stream: rtsp://ADMIN:password@IP/ch1/stream3;

4.3.13 IP Filter

The IP filter interface allows you to add IP addresses that have access permission (i.e., white list) and those that do not have access permission (i.e., black list) and to configure the IP Filter Mode.

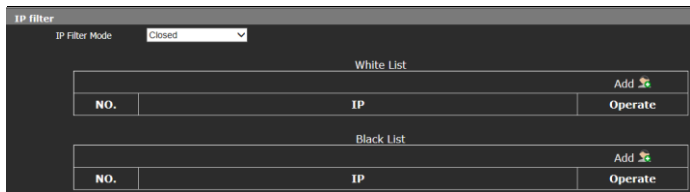

The screenshot shows the 'IP filter' interface. At the top, there is a dropdown menu for 'IP Filter Mode' set to 'Closed'. Below this are two sections: 'White List' and 'Black List'. Each section contains a table with columns for 'NO.', 'IP', and 'Operate'. An 'Add' button with a plus icon is located to the right of each table.

White List		
NO.	IP	Operate

Black List		
NO.	IP	Operate

Figure 4-25

Click the icon **Add**  to add IP address on the popup page.



The screenshot shows a popup form for adding an IP address. It includes a label 'IP type:' with a dropdown menu set to 'IPv4 address', a label 'IP address:' with a text input field, and two buttons: 'Save' and 'Cancel'.

Figure 4-26

Click the **Save** button after an IP address is added. Then the added IP address will appear in the appropriate IP list.

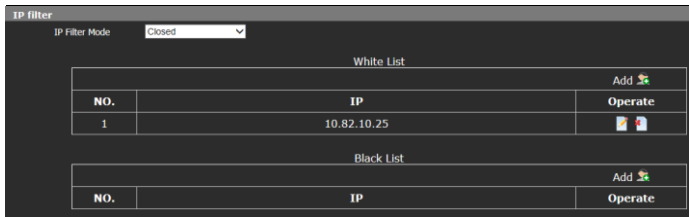

Figure 4-27

If you select the white list mode under the IP Filter Mode, only the IP addresses that are added to the white list are able to be accessed. If you select the black list mode under the IP Filter Mode, the IP addresses that are added to the black list cannot access the device.

Note: If the white list mode is selected, a valid IP address must be available; be sure to remember the IP address.

On the IP list, in the Operate column, use the icon “✖” to delete and “✎” to edit.

4.3.14 Monitor Connect

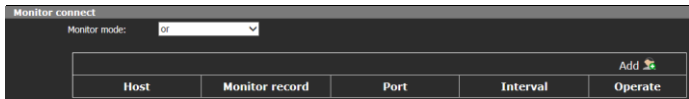



Figure 4-28 Monitor Connect

You can monitor connection status of devices and platform on the **Monitor Connect** page. You can also use settings on the **Alarm** page to assure automatic recording when disconnecting.

Procedures:

1. Click **Add**  icon to set **Host IP** (the IP of computer where the server platform is located), **Port** and **Interval**.

2. On **Alarm** page, select **Heart Beat Lost** and **SD Card** and then set alarm time. For more information, see “Alarm Settings” in section 4.7.

3. SD card will record automatically when a disconnection between devices and platforms is monitored, and it stops recording one minute after the devices and platforms reconnect.

Monitor Mode: “Or” and “And” are selectable. When the monitor mode is “Or,” SD card will be enabled when one of the platforms disconnects; when the monitor mode is “And,” SD card will be enabled when all of the platforms disconnect.

4.4 Camera Settings

Click “Camera” in the navigation bar to enter the interface shown below:

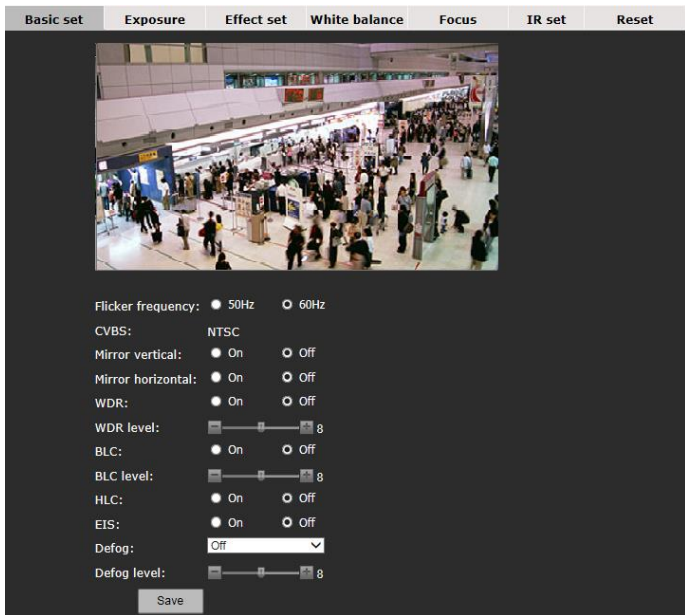

Figure 4-29 Basic Settings

There are 7 option tabs included in the camera settings page: Basic set, Exposure, Effect set, White balance, Focus, IR set and Reset.

4.4.1 Basic Settings

Basic settings allows the following parameters to be configured:

Flicker frequency: 50Hz or 60Hz.

CVBS: Automatically changes depending on the flicker frequency. (Note:

analog videos are shut off after MJPEG stream is enabled. To enable analog videos, disable MJPEG stream.)

Enable or disable (On/Off): mirror vertical, mirror horizontal, WDR, BLC, HLC and EIS (stabilization).

Defog: Optional, set to Auto or Off.

Defog level: If set to Auto, set the defog level, 0~16.

Be sure to save settings before leaving the interface or cancel any changes made.

4.4.2 Exposure Settings

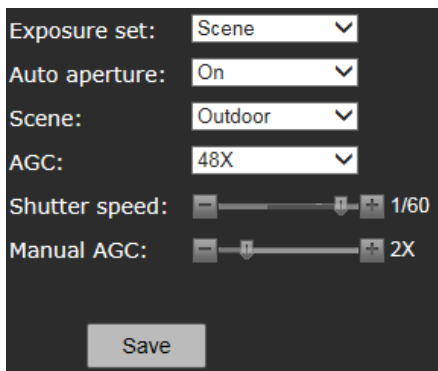

Figure 4-30 Exposure Settings

From this screen, set Exposure set, Auto aperture, Scene, AGC, Shutter speed and Manual AGC.

Exposure Set: Select Manual, Scene and Shutter priority from the dropdown.

Auto Aperture: Enable or disable autoiris.

Scene mode: Indoor or outdoor can be selected.

AGC: Select from 8X, 16X, 32X, 48X, 64X options; if set to Manual Exposure mode, Shutter speed can be set from 1/30s to 1/10000s and manual AGC can be

set as 1X, 2X, 4X, 8X, 16X, 32X, and 64X, but then scene and AGC are not adjustable; if set to Shutter priority mode, the Min shutter speed (1/100s~1/32000s adjustable), Max shutter speed (1/1s~1/32000s adjustable) and AGC can be set.

Be sure to save settings before leaving the interface or cancel any changes made.

4.4.3 Effect Settings

In the Effect Settings interface, users can adjust the brightness, sharpness, hue, contrast, saturation and 3D de-noise (DNR) in two ways, General or Mode, as shown in the figure below:

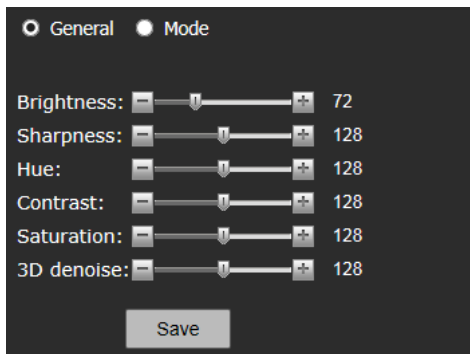

Figure 4-31 Effect Set - General

General: Drag the sliding block to adjust the brightness, sharpness, hue, contrast, saturation and 3D de-noise (DNR) parameters.

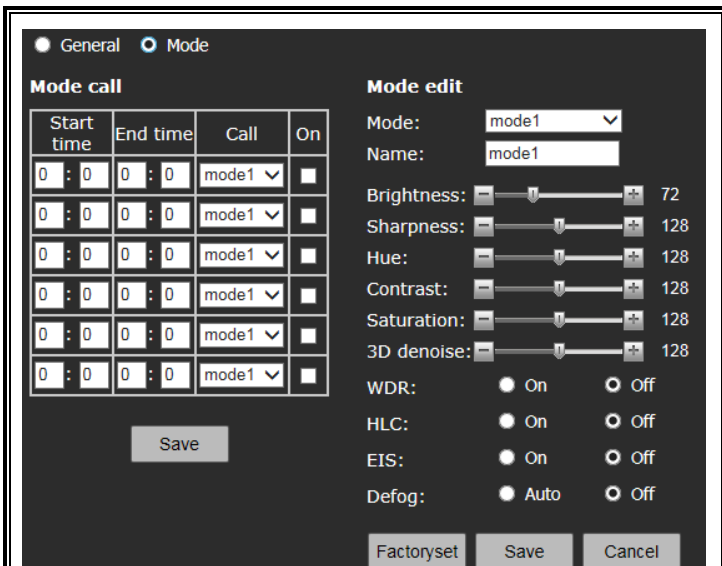

Figure 4-32 Effect Set - Mode

Mode: The camera supports 6 video effect modes. Users can set and save a Name, Brightness, Sharpness, Hue, Contrast, Saturation, 3D de-noise, WDR, HLC, EIS and Defog for each mode. Click “Factoryset” to restore default settings.

In the Mode call, users can set Effect Mode call status and start and end period. Be sure to save settings before leaving the interface or cancel any changes made.

4.4.4 White Balance

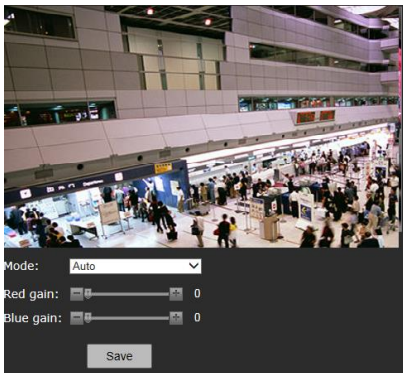

Figure 4-33 White Balance Settings

The camera has a selection of white balance modes, including Auto and Outdoor. If set to Manual mode, the red gain and blue gain can be set.

Be sure to save settings before leaving the interface or cancel any changes made.

4.4.5 Focus Settings

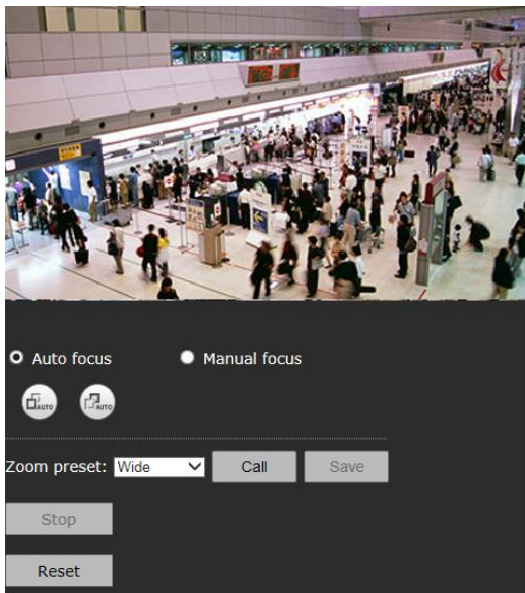



Figure 4-34 Focus Settings

The camera has a built-in motorized zoom lens for remote focal length adjustment. Click “Focus” in camera settings interface to enter focus settings. On this page, select focus mode, zoom/focus and call focus limit.

Auto focus:

In auto focus mode, the interface is shown as Figure 4-33.

Click  button to focus wide; click  button to focus tele.

Click Stop button during focusing to stop auto focus.

Left-click in one section of the video; the frame of this section will turn to green and the camera will automatically focus for this area.

Manual focus: Click Manual focus to enter the interface shown below.

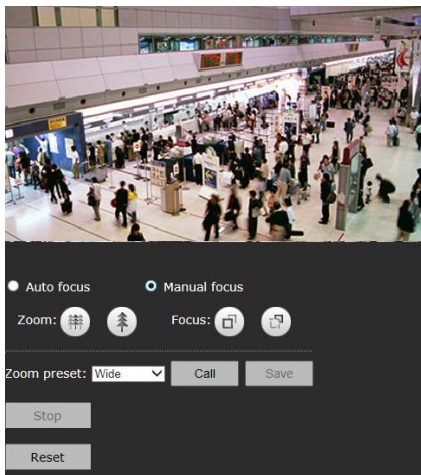





Figure 4-35

Click   to zoom wide/zoom tele.

Click   to focus near/focus far.

Focus Limit: The camera can call a focus limit. There are 5 options: Wide, Middle, Tele, User set 1, User set 2. The effects for Near, Middle and Far are default; but User set 1 and User set 2 can be specified by users.

Reset: If the camera cannot focus clearly using auto focus, click Reset button to restart the motor.

Be sure to save settings before leaving the interface or cancel any changes

made.

4.4.6 IR Set

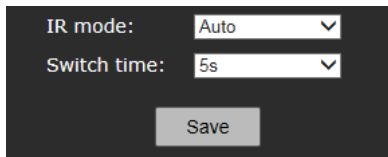

IR mode: Auto

Switch time: 5s

Save

Figure 4-36

IR mode: Set IR illuminators working mode.

Options: Day, Night, Auto (turn on or off as per ambient light).

Switch time: In auto mode, the response time for day/night switch.

Be sure to save settings before leaving the interface or cancel any changes made.

4.4.7 Reset

From this interface, restore all the camera parameters to the factory default settings.

4.5 Video and audio Settings

Click the button Video and audio in the navigation bar to display the following interface.

Video OSD Motion Privacy ROI Path Audio Reset

H.265 H.264

Major stream Minor stream Third stream

Resolution:	2592x1944	Resolution:	720x576	Stream type:	MJPEG
Frame rate:	15	Frame rate:	25	Resolution:	640x480
GOP number:	60	GOP number:	30	Frame rate:	5
Smart codec:	Off	Smart codec:	Off	Image quality:	Highest
Bit rate control:	CBR	Bit rate control:	CBR		
Bit rate:	4000 kbps (256~10000)	Bit rate:	2000 kbps (256~2000)		

Save Save Save

Figure 4-37 Video Settings

The Video and audio Settings page allows setting Video, OSD, Motion, Privacy, ROI, Path, Audio and Reset.

Click the related option tab to enter the setting interface.

4.5.1 Video Settings

Users can set the video parameters for H.265, H.264 and MJPEG stream, including resolution, frame rate, GOP number, and bit rate.

For H.265/H.264 major stream, the resolution comes up to 2592×1944, with 2560×1920, 2048×1536, 1920×1080, 1280×960 and 1280×720 optional;
For H.265/H.264 minor stream, the resolution comes up to 720×576, 704×576, 640×480, 352×288, 320×240 and closed.

Resolution for third stream:

For the third stream, the stream type can be set as H.264, H.265 and MJPEG.
The resolution can be 640×480/352×240/320×240.

Frame Rate: This is the number of compressed frames produced by the camera per second. The larger the frame rate is, the better the image continuity will be, but the CPU performance is lowered. The smaller the frame rate is, the worse the image continuity will be, but the CPU can handle more events.

The maximum frame rate for H.265 and H.264 is 30fps. The maximum frame rate for MJPEG is 5fps.

The Max. Encoding Capacity is 2592×1944@30fps+720×480@30fps+ MJPEG640×480@5fps.

GOP number: GOP number is the ratio of I frame (complete image) to P frame (changes in image) in compressed video images. The larger the value is, the less the data quantity is and the less network resource it occupies.

Max. GOP number can be set to 60.

Bit Rate: There are 2 modes of bit rate: variable rate (VBR) and constant rate (CBR).

With variable bit rate, the system can automatically adjust the bandwidth of the images per the complexity of the images. In practical use, the complexity of the video images varies constantly, as the details of the scene and the moving speed change. If the video includes too much detail and images in it move fast, then the bandwidth it uses will be larger. If not, the bandwidth is smaller. If the Bit Rate is set as “Constant bit rate,” then the images are transferred by fixed

bandwidth capacity, no matter how the complexity of the images changes.

Bit Rate: If “VBR” is selected, the upper limit of bit rate has to be set; if “CBR” is selected, the stream size will be fixed and the stream size is defined in the “Bit Rate.” For major stream, the bit rate upper limit can be 256kbps~10000kbps; for minor stream, the bit rate upper limit can be 256Kbps~2000Kbps.

Image Quality: Set under MJPEG (third) stream. Options: Highest, High, Average, Low and Lowest. The higher the image quality is, the more bandwidth it will use.

4.5.2 OSD

Mode: MarginX/Y(0-20):

Text1: Text Image Off X/Y(0-99):

Context2: Text Off

Context3: On Off Size: X/Y(0-99):

Line1: Align:

Line2: 1-2Interval:

Line3: 2-3Interval:

Line4: 3-4Interval:

Line5: 4-5Interval:

Date OSD: On Off Size: X/Y(0-99):

Time format:

Figure 4-38 OSD

From the OSD (On Screen Display) screen, set Text 1, Context 2, Context 3 and date to display on the video image.

Mode: BlackEdge (text has a black outline) or SingleColor.

Margin: Set the margin of the text overlay area from the edge of image; 1 indicates one-tenth character size and 10 indicates one character size. For example, set X to 10 and Y to 20, which means the left side of text area is only one character size from the left edge of image and the upper side of the text area is 2 character sizes from the upper edge of the image.

Note that the size of overlay characters can be set separately. When the character sizes are not the same, the actual margin size is different, even if the same margin is set. For example, for Context 3, if the font size is set to 3 point, a margin of 1 indicates the size of one-tenth of 3 point font; for Text 1, if the font size for text is set to 8 point, the margin of 1 indicates the size of one-tenth of 8 point font.

Text 1: Text or Image options or turn the option Off.

Text: Select Text and enter the text content in the content box, which allows up to 40 characters (a~z, A~Z and 0~9). Also set the font size and text coordinates (where the text will display on the screen).

Image: The camera supports image overlaying on the video, for example inserting a logo. Click Image to set the image overlay information. Click the Browse button, select the image to be uploaded, and then, click Upload. Drag the slider for transparency to adjust the image transparency. Select “Clean white” to make a transparent background for the image. Additionally, set the coordinates for the image for where it will display.

Notes:

- (1) A bitmap image is required.
- (2) The maximum size of image is 352×288, with both the width and height required to be an even number, such as 160×130.

Context 2: Select “On” and enter the text content in the text box, which allows

up to 40 characters (a~z, A~Z and 0~9). Also set the font size and text coordinates.

Context 3: Select “On” and enter the text content in the text box from line 1 to 5, which allows up to 40 characters (a~z, A~Z and 0~9). Also set the font size and text coordinates.

Align: Multiple lines of texts can be aligned at the left or right. Set the interval between two lines that are next to each other; 1 indicates the one-tenth size of a character.

Note: X/Y Coordinate: Set the coordinates of text. For text 1, Context 2 and Context 3, the origin of coordinates is the upper left corner of the text display area.

Date OSD: Select “On” and set the font size, display position and format (MMDDYYYY, DDMMYYYY or YYYYMMDD). Size: Set the character size of the text. The larger value indicates larger character size.

After settings are finished, click the “Save” button. The OSD displays on the video. To cancel OSD, click “Off” and “Save” button.

4.5.3 Motion Detection

The screenshot displays a configuration window for motion detection. It features four vertically stacked sections, each representing a motion zone (Zone1 through Zone4). Each zone section includes a square checkbox on the left, a 'Draw' button, a text input field for 'Name', a 'Sensitivity' slider currently set to 50, and 'Save' and 'Cancel' buttons. Below these zones is a 'Museum search sensitivity' slider set to 80, also with 'Save' and 'Cancel' buttons.

Figure 4-39 Motion Detection Settings

The motion detection function is supported. Up to 4 motion zones can be configured.

Note: Turn on motion detection function in Live View interface before motion detection setting (see Section 4.1).

Check the box of the Zone number to be set. If this motion detection area has already been set, a blue frame will be displayed on the screen.

Setting the motion detection area:

Check the box of motion detection area number. Click the “Draw” button with the mouse and then left click on the mouse and draw a blue frame on the screen. Then, click the “Save” button to save the zone; the blue frame will turn green, indicating the setting is complete.

Enter the area name in the Name field and use the slide bar to set the sensitivity; moving the slide towards the plus sign heightens the sensitivity for detection. To cancel a motion detection area, uncheck the box.

Museum search, one of the recorded video playback search functions, allows the search for moving objects in recorded video. Museum search sensitivity is the threshold for regulating the smallest moving range objects that can be searched. Use the slide bar to adjust the Museum search sensitivity.

4.5.4 Privacy Mask

V945D Series camera supports 4 privacy masks. If certain sensitive areas within the surveillance area should not be viewed, a Privacy Mask can be applied. The camera system covers and shields the sensitive area via Privacy Mask setting to prevent operators from observing this location.

Note: Turn on the privacy mask function in Live View interface before privacy mask setting (see Section 4.1).

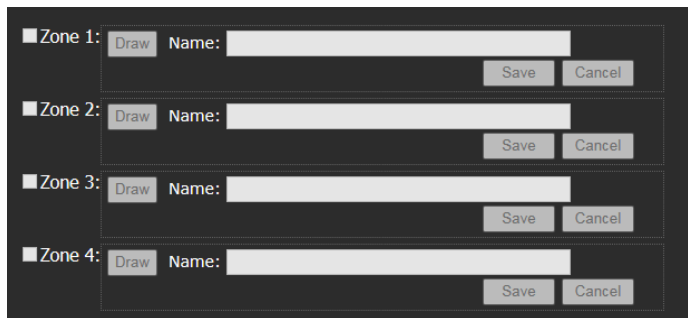

Figure 4-40 Privacy Mask Settings

How to set the privacy masks:

Check the box of privacy Zone number. Click the “Draw” button with the mouse and then left click on the mouse and draw a blue frame on the screen. Then click the “Save” button and the blue frame changes into black, masking that area of the image.

To cancel a privacy mask, uncheck the box.

4.5.5 ROI

The camera supports ROI (Region of Interest) function, with eight zones settable. The areas selected are of particular importance in the scene, for example a face or license plate. When this enabled, the selected areas will be encoded to include more detail.

The image shows a software interface for configuring ROI settings. It consists of eight vertically stacked sections, each representing a zone from Zone 1 to Zone 8. Each zone section contains the following elements: a square icon with a zone number, a 'Draw' button, a text input field for 'Name', a 'Definition' value of 50, a horizontal slider bar with minus and plus end caps, and 'Save' and 'Cancel' buttons.

Figure 4-41 ROI Settings

ROI settings method:

Check the Zone number of the region for setting and click the “Draw” button. Left click on the mouse and draw a blue frame on the screen. Click the “Save” button and when the color of the regional border changes from blue to green, ROI setting is complete. Use the slide bar to adjust the definition of the region.

To cancel an ROI, uncheck the box.

4.5.6 Storage Path

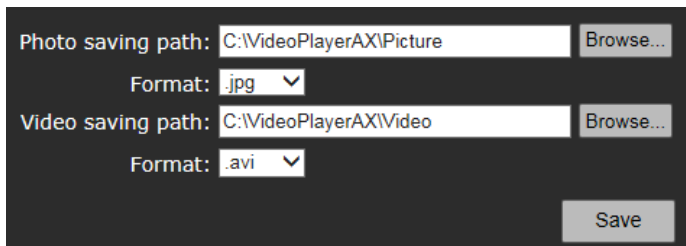

The screenshot shows a settings dialog box with a dark background. It contains two rows of controls. The first row is for 'Photo saving path', with a text input field containing 'C:\VideoPlayerAX\Picture' and a 'Browse...' button to its right. Below this is a 'Format:' label followed by a dropdown menu showing '.jpg'. The second row is for 'Video saving path', with a text input field containing 'C:\VideoPlayerAX\Video' and a 'Browse...' button to its right. Below this is a 'Format:' label followed by a dropdown menu showing '.avi'. At the bottom right of the dialog is a 'Save' button.

Figure 4-42 Storage Paths

The default photo saving path: C:\VideoPlayerAX\Picture.

The default video saving path: C:\VideoPlayerAX\Video.

The photo and video formats can be set. The default photo format is .jpg and the default video format is .avi.

To change the saving path, click the “Browse” button and select the path from the popup dialog box.

4.5.7 Audio Settings

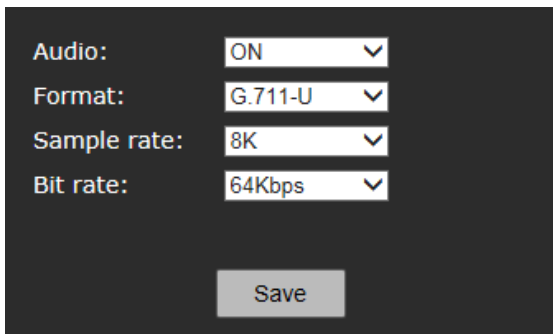

The screenshot shows an audio settings dialog box with a dark background. It contains four rows of controls, each with a label and a dropdown menu. The first row is 'Audio:' with a dropdown showing 'ON'. The second row is 'Format:' with a dropdown showing 'G.711-U'. The third row is 'Sample rate:' with a dropdown showing '8K'. The fourth row is 'Bit rate:' with a dropdown showing '64Kbps'. At the bottom center of the dialog is a 'Save' button.

Figure 4-43 Audio Settings

Audio: ON or OFF options.

Format: G.711-U, G.711-A and AAC.

Sample rate: For G.711-U, G.711-A, sample rate is 8K; for AAC, sample rate options are 16K, 32K, 44.1K, 48K.

Bit rate: For G.711-U, G.711-A, bit rate is 64Kbps; for AAC, bit rate options are 32K, 64K.

4.6 Video Content Analysis Functions

Click the “Video Content Analysis” button on the left navigation bar. The setting page for the VCA functions shows as below:

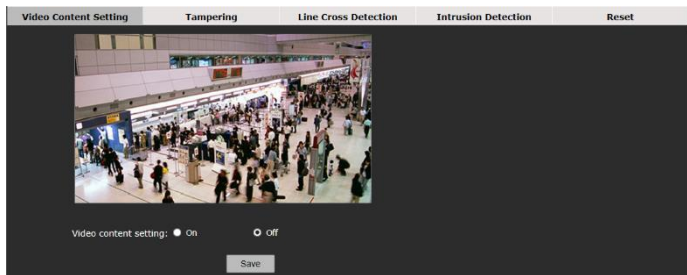

Figure 4-44 Settings of Video Contents Analysis Functions

From the Video Content Analysis tab, set Camera Tampering, Line Cross Detection and Intrusion Detection. Click the tabs respectively to enter each setting page.

In the VCA setting page, users can enable or disable the VCA function to allow setting the other functions.

4.6.1 Camera Tampering

From this screen, set the sensitivity for scene changes, defocus detection and low or high brightness detection.

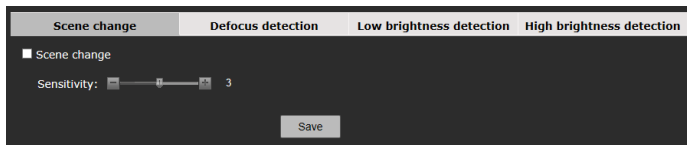

Figure 4-45 Scene change



Figure 4-46 Defocus detection

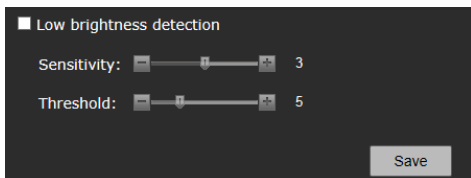

Figure 4-47 Low brightness detection

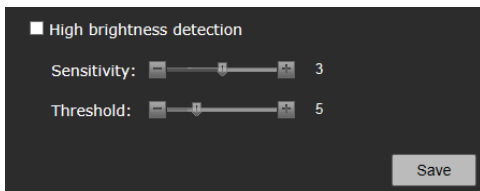

Figure 4-48 High brightness detection

Scene change: When the monitoring scene changes, an alarm is triggered.

Defocus detection: When focus is not clear, an alarm is triggered.

Low brightness detection and High brightness detection: When the low brightness or high brightness is detected, an alarm is triggered.

Under Scene change, set the sensitivity. Sensitivity varies from 1 to 5.



Under Defocus Detection, Low brightness detection, and High brightness detection, set the sensitivity and threshold. Sensitivity varies from 1 to 5 and threshold from 0 to 20.

4.6.2 Line Cross Detection



Figure 4-49 Line Cross Detection

The camera supports line cross detection. This allows the placement of four virtual lines on the scene, marking where the allowed and prohibited entry direction is. These are set using the mouse. When people or objects cross a line in the wrong direction, an alarm is triggered.

Note: Enable the VCA functions in the Live view page ( ) before setting the line cross detection function (refer to Section 4.1).

From the Settings page, select Line Cross. Check Line Cross Detection to enable the function. If a line has been placed, a green line with two direction arrows appears on the screen. The solid arrow indicates the prohibited direction while the hollow arrow indicates the allowed direction.

Draw a virtual line:

To draw a virtual line, select Line 1. Click the Begin button with the mouse, place a start point on the screen, move the mouse and place an end point on the screen. Then click the direction arrows on the line to set it solid or hollow.

When finished, click the End button. To edit a line, click the green line until it turns blue with red endpoints. Then click the endpoints and move the mouse to edit the line.

To redraw the line, click the Cancel button and draw it again.

When finished, click the “Save” button to save the line.

Set the sensitivity and threshold of the line cross detection function.

4.6.3 Intrusion Detection

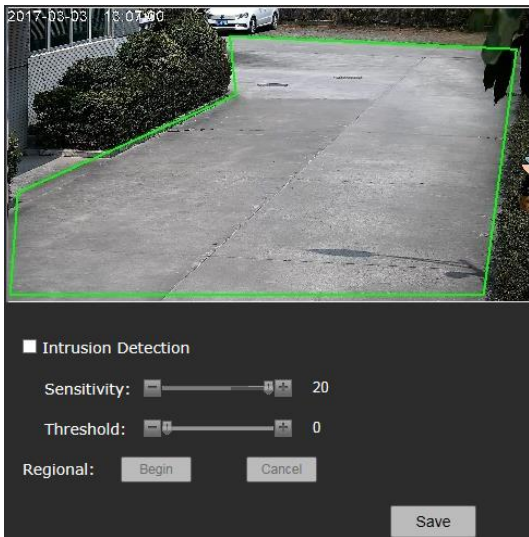

Figure 4-50 Intrusion Detection

The camera supports Intrusion Detection. One intrusion detection area can be set. When objects move into this area, an alarm is triggered.

Check “Intrusion Detection” to enable the function. If an area has been set, a green frame appears on the screen. If not, a default rectangle frame appears.

Draw an intrusion detection area:

Click the Begin button and then left-click the mouse on the video to draw the first point; move the mouse and left click to draw the second point, and so on. Up to eight points can be drawn. When the last point is drawn, move the mouse to the first point. When a small red box appears, click to display a green closed area.

Note: Up to eight points are allowed. After the last point is drawn, a green area from the first point to the last point appears automatically.

When the area is finished, click the End button. To edit the area, click the green frame of the area. When the frame turns blue from green, click the points and move the mouse to change the area.

To redraw the area, click the Cancel button and draw it again.

When finished, click the “Save” button to save the area.

The sensitivity and threshold of the Intrusion Detection function can also be set.

4.7 Alarm Settings

Click “Alarm” in the left navigation bar to display the following Alarm Settings interface:

Alarm configuration

I/O In1:
I/O In2:
Alarm out contact:
Alarm server 1 IP:
Alarm server 2 IP:
Alarm server 3 IP:

Alarm out contact

Note: Enable MJPEG before Mail or FTP is selected.

	I/O out 1	Mail	SD card Photograph	SD card Recording	FTP	Audio	Select all
I/O In 1	<input type="checkbox"/>	<input type="checkbox"/>	<input type="checkbox"/>	<input type="checkbox"/>	<input type="checkbox"/>	<input type="checkbox"/>	<input type="checkbox"/>
I/O In 2	<input type="checkbox"/>	<input type="checkbox"/>	<input type="checkbox"/>	<input type="checkbox"/>	<input type="checkbox"/>	<input type="checkbox"/>	<input type="checkbox"/>
Motion zone 1	<input type="checkbox"/>	<input type="checkbox"/>	<input type="checkbox"/>	<input type="checkbox"/>	<input type="checkbox"/>	<input type="checkbox"/>	<input type="checkbox"/>
Motion zone 2	<input type="checkbox"/>	<input type="checkbox"/>	<input type="checkbox"/>	<input type="checkbox"/>	<input type="checkbox"/>	<input type="checkbox"/>	<input type="checkbox"/>
Motion zone 3	<input type="checkbox"/>	<input type="checkbox"/>	<input type="checkbox"/>	<input type="checkbox"/>	<input type="checkbox"/>	<input type="checkbox"/>	<input type="checkbox"/>
Motion zone 4	<input type="checkbox"/>	<input type="checkbox"/>	<input type="checkbox"/>	<input type="checkbox"/>	<input type="checkbox"/>	<input type="checkbox"/>	<input type="checkbox"/>
Line Cross Detection	<input type="checkbox"/>	<input type="checkbox"/>	<input type="checkbox"/>	<input type="checkbox"/>	<input type="checkbox"/>	<input type="checkbox"/>	<input type="checkbox"/>
Intrusion Detection	<input type="checkbox"/>	<input type="checkbox"/>	<input type="checkbox"/>	<input type="checkbox"/>	<input type="checkbox"/>	<input type="checkbox"/>	<input type="checkbox"/>
Scene change	<input type="checkbox"/>	<input type="checkbox"/>	<input type="checkbox"/>	<input type="checkbox"/>	<input type="checkbox"/>	<input type="checkbox"/>	<input type="checkbox"/>
Defocus detection	<input type="checkbox"/>	<input type="checkbox"/>	<input type="checkbox"/>	<input type="checkbox"/>	<input type="checkbox"/>	<input type="checkbox"/>	<input type="checkbox"/>
Low brightness detection	<input type="checkbox"/>	<input type="checkbox"/>	<input type="checkbox"/>	<input type="checkbox"/>	<input type="checkbox"/>	<input type="checkbox"/>	<input type="checkbox"/>
High brightness detection	<input type="checkbox"/>	<input type="checkbox"/>	<input type="checkbox"/>	<input type="checkbox"/>	<input type="checkbox"/>	<input type="checkbox"/>	<input type="checkbox"/>
SD card out	<input type="checkbox"/>	<input type="checkbox"/>	-	-	<input type="checkbox"/>	<input type="checkbox"/>	<input type="checkbox"/>
Network link down	<input type="checkbox"/>	-	<input type="checkbox"/>	<input type="checkbox"/>	-	<input type="checkbox"/>	<input type="checkbox"/>
Heart beat lost	-	-	<input type="checkbox"/>	<input type="checkbox"/>	-	-	<input type="checkbox"/>

Alarm schedule

	Start time	End time
<input type="checkbox"/> Sun.	00 : 00	00 : 00
<input type="checkbox"/> Mon.	00 : 00	00 : 00
<input type="checkbox"/> Tue.	00 : 00	00 : 00
<input type="checkbox"/> Wed.	00 : 00	00 : 00
<input type="checkbox"/> Thu.	00 : 00	00 : 00
<input type="checkbox"/> Fri.	00 : 00	00 : 00
<input type="checkbox"/> Sat.	00 : 00	00 : 00
<input type="checkbox"/> Everyday	00 : 00	00 : 00

Figure 4-51 Alarm Settings

Alarm Configuration

The camera supports 2 alarm inputs, I/O in 1 and I/O in 2 and 1 alarm output, I/O out. Users can set the status of each alarm input: Grounded Circuit or Open

Circuit. Grounded Circuit: “0;” Open Circuit: “1.”

Alarm out Contact: Set the transfer mode of the alarm signal, Local contact or Net contact.

Local Contact: I/O out is triggered by I/O alarm in, motion detection alarm, video contents analysis, TF card out, network link down or heart beat lost.

Default: Local Contact.

When the value of I/O out 1 is “1,” the switch status will be on.

When the value of I/O out 1 is “0,” the switch status will be off.

Net Contact: I/O out is controlled by the surveillance management software.

Note: This function can work with some Digital Video Surveillance Management software. If Net contact is selected, users must set the IP of the Alarm server as the server IP of the system. After the necessary settings in software, users can control the relay switches remotely via the software. For detailed information, refer to the Digital Video Surveillance Management Software Operation manual.

Alarm Server IP: Set the IP address of alarm server. When an alarm occurs, the alarm server is notified.

Alarm out Contact

Users can set the responding action for each switch signal I/O alarm in, motion detection alarm, video contents analysis, TF card out, network link down or IP address conflict from the options: Alarm out 1 (if Net Contact is selected, this option is unavailable), TF card, Mail, FTP or Audio. When setting is completed, click “Save” button.

Note: When “FTP” or “Mail” is selected, FTP or SMTP parameters must be set in Network Settings; refer to Section 4.3.2 or Section 4.3.3 for details.

Alarm Schedule

The effective alarm schedule can be set. Users can select the alarm period. For example, if Sunday is selected, on each Sunday the alarm will be in effect in the set time; if Everyday is selected, alarm will be in effect in the set time every day. The start time and end time is set up in the 24-hour format. The end time must be after the start time. Press the “Save” button to activate the settings.

4.8 Storage Management

The camera supports storage with TF card. Click the Storage button to display the Storage Management interface to set the recording parameters, replay and download the recorded videos.

4.8.1 Storage Settings for Recording

Capture settings

Record picture: Open Close
Capture Type: Alarm trigger
Capture interval: 1s

Recording control

Recording video type: Major Stream
Recording audio: Open Close
Prerecorded time: No record
Delay time: 5s
Recording mode: Always
SD card full: Overwrite

Peripheral equipment manage

SD card	Total capacity	Percentage of video capacity	Video capacity	Picture capacity	Remaining available capacity	State
1	0KB	0%	0KB	0KB	0KB	No card

Figure 4-52 Storage Settings

Capture Settings:

Record picture: Open or close picture record.

Capture Type: Alarm trigger

Capture interval: Set the capture interval (in seconds).

Recording control:

Recording video type: Select the type of videos to record, major stream or minor stream.

Recording audio: Open or close audio recording.

Prerecorded time: Select prerecord time in seconds, No record or No limit.

Delay time: Select delay time from 5s up to 10 minutes.

Recording mode: Set the recording mode; choose from Alarm triggered, Always or Close options. When Alarm triggered is selected, and the setting of alarm associated with TF card is set in the alarm interface (refer to section 4.7), when the alarm occurs, recording is triggered automatically.

SD card full: Select what happens when the SD card is full from Overwrite or Stop options. In Overwrite mode, when the TF card is full, the newly recorded videos automatically overwrite the old videos; in Stop mode, when the TF card is full, recording stop automatically.

Peripheral equipment:

View the total size, used space and state of TF card and also format it.

4.8.2 Replay

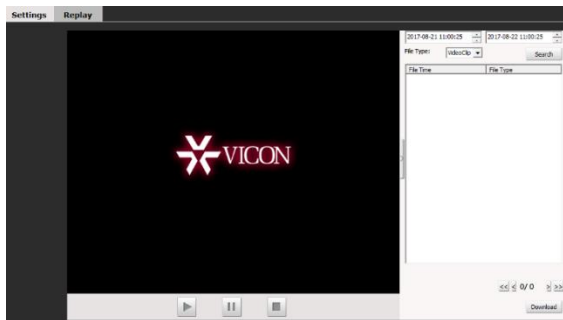







Figure 4-53 Replaying

Video Search: Set the start and end times at the top right and then click the Search button. The recordings during this period of time will be listed.

Replay: To replay a video, double click the recording file in the list or select a file and then press the “Play” button . During playback, click  or  to pause or stop the playback.

Click the  button on the right of video window to collapse the right window and view the video full screen. Click the  button to return to the page as Figure 4-53.

Download: The videos stored in the TF card can be downloaded to a local PC. Select the file from the video list (multiple files can be selected simultaneously using the “Ctrl” or “Shift” key) and then click the “Download” button to enter the downloading interface.

Save to: Set the path to save the downloaded files. The default local storage path is displayed. If a different location is required, click the “Browse” button.

AVI/H.264 drop-down list box: Select the downloaded file format.

In the download list, file total size, status and download progress will display.

Click the “Start” button and the files in the list will be downloaded in order.

The progress shows 100% when downloading is finished.



Click the “Open” button to enter download content.

4.9 User Settings

The default admin user is ADMIN (uppercase; password: 1234). The admin can add or delete other users and change their passwords. The user name ADMIN cannot be changed but it is recommended to change the ADMIN password for increased security. A maximum of 7 users are supported.

Detailed instructions on how to add and delete users are addressed below.

Click the Users option tab in the Settings interface; the following user information will display. The “Num” item shows the number of the user and

then the user name. The “Property” column shows the authority of the user. In the “Operation” column, use  to delete and  to edit user information. See figure below:



Add user 			
Num	User name	Property	Operation
1	ADMIN	 Admin	

Figure 4-54 User Settings

1. Add Users

(1) Click “Add user ” to open the “Add a User” interface.

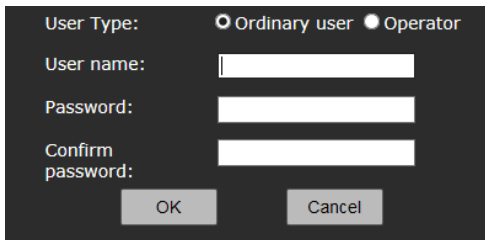

Figure 4-55 Add a User

(2) Enter the desired User Name and Password (user name and password can include letters, numbers and underline only. No special characters are allowed. The string length of user name can be between 1 and 30 characters and that of the password is between 5 and 20 characters).

For the User Type, select Ordinary user or Operator. An ordinary user can view videos and an Operator can view videos and configure video settings.

(3) Click “OK” button. If the setting is successful, the new user name will appear in the account list, like new user “user1” in the example below:





Num	User name	Property	Operation
1	ADMIN	Admin	
2	user1	Ordinary user	 

Figure 4-56

2. Delete Users

In the “User setting” interface, click  button under “Operation” for the user to be deleted. The following dialog box will display:

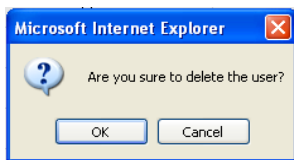



Figure 4-57

Click “OK” button; the selected user will be deleted and the user list is automatically updated.

3. User Password Change

Click  button in the user list and the Edit User Information dialog box pops up:

User name:

Old password:

New password:

Confirm password:

Figure 4-58

Input the old password, enter the desired new password (twice, once to confirm) and then click “OK” button; the following popup will display; click OK:

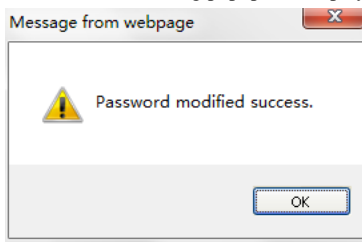

Figure 4-59

4.10 System Log

Click the “Log” option tab to enter the system log interface. The date, time and log information will appear on the screen.

Date	Time	Log
2017-05-27	14:44:05	app: User:user1 's password is changed!
2017-05-27	14:28:54	app: Add new User user1 Privilege: 4
2017-05-21	12:08:18	app: system start!!
2017-05-21	12:07:10	app: change IP to 10.82.19.120
2017-05-21	00:03:45	app: system start!!
2017-05-21	20:56:47	app: system start!!
2017-05-21	20:59:46	app: change IP to 10.82.19.120
2017-05-21	20:46:44	app: system start!!
2017-05-16	15:12:02	app: change ip to 10.82.19.86
2017-05-16	15:12:02	app: change gateway to 10.82.19.1
2017-05-16	15:00:49	app: system start!!
2017-05-08	16:20:27	app: Get a perimeter alarm.
2017-05-08	16:20:20	app: Get a perimeter alarm.
2017-05-08	16:20:07	app: Get a perimeter alarm.
2017-05-08	14:36:20	app: Get a img color rep err alarm.
2017-05-08	14:36:17	last message repeated 3 times
2017-05-08	14:35:55	app: Get a img color rep err alarm.
2017-05-08	14:35:53	app: Get a vca img color rep err alarm.
2017-05-08	14:35:36	app: Get a vca img color rep err alarm.
2017-05-08	14:35:36	app: Get a img color rep err alarm.
2017-05-08	14:35:19	app: Get a vca img color rep err alarm.
2017-05-08	14:35:18	app: Get a img color rep err alarm.
2017-05-08	14:35:01	app: Get a vca img color rep err alarm.
2017-05-08	14:34:01	app: Get a img color rep err alarm.
2017-05-08	14:34:44	app: Get a vca img color rep err alarm.
2017-05-08	14:34:44	app: Get a img color rep err alarm.
2017-05-08	14:34:27	app: Get a img color rep err alarm.
2017-05-08	14:34:10	app: Get a vca img color rep err alarm.
2017-05-08	14:34:09	app: Get a img color rep err alarm.
2017-05-08	14:33:40	app: Get a img color rep err alarm.

Figure 4-60

Up to 30 logs can display on a page. The user can turn over the page by clicking the arrows at the bottom or skip to a designated page by clicking Goto. To remove a log, click “Delete logs;” a prompt will display. Click “Yes” to clear

logs.

APPENDIX I QUESTIONS & SOLUTIONS

The following table describes the symptoms, causes and solutions for the problems.

Symptoms	Possible Causes	Solutions
The network camera does not perform initiation after power-on	Wrong power connection	Reconnect power cable
	Power supply failure	Repair or replace power supply
	Immediate startup after power-off	Restart 10 seconds later after power-off
	If PoE power supply is used, too long transmission distance may make the power of the Power Supply Switcher insufficient.	Shorten the length of the power supply network cable or replace Power Supply Switcher with more power
	If PoE power supply is used, connection to other electric appliance makes the ground level not in correct level.	Disconnect other electrical appliances
No video signal displayed	The plug-in for viewing image is installed incorrectly.	Refer to the plug-in installation to reinstall it
	Network camera's IP address conflicts with other user's IP address	Set a unique IP address
Vague image	Manual focus is not precise	Carefully manually adjust the camera focus

SHIPPING INSTRUCTIONS

Use the following procedure when returning a unit to the factory:

1. Call or write Vicon for a Return Authorization (R.A.) at one of the locations listed below. Record the name of the Vicon employee who issued the R.A.

Vicon Industries Inc.

135 Fell Court

Hauppauge, NY 11788

Phone: 631-952-2288; Toll-Free: 1-800-645-9116; Fax: 631-951-2288

For service or returns from countries in Europe, contact:

Vicon Industries Ltd

Unit 4, Nelson Industrial Park,

Hedge End, Southampton

SO30 2JH, United Kingdom

Phone: +44 (0)1489/566300; Fax: +44 (0)1489/566322

2. Attach a sheet of paper to the unit with the following information:
 - a. Name and address of the company returning the unit
 - b. Name of the Vicon employee who issued the R.A.
 - c. R. A. number
 - d. Brief description of the installation
 - e. Complete description of the problem and circumstances under which it occurs
 - f. Unit's original date of purchase, if still under warranty
3. Pack the unit carefully. Use the original shipping carton or its equivalent for maximum protection.
4. Mark the R.A. number on the outside of the carton on the shipping label.



VICON INDUSTRIES INC.

For office locations, visit the website: www.vicon-security.com

