



VAX Vicon Access Control Software

A full-featured, browser-based
access control platform for
any size operation



Overview

Vicon Access Control (VAX) is an enterprise-grade, browser-based access control system engineered to protect people, property and assets through a world-class, user-friendly interface. Users can customize their access control with ease, while reducing installation and maintenance costs with features like user templates and our Data Migrator tool. Users can also integrate VAX with Valerus VMS to centralize their access control and video monitoring system into a powerful, end-to-end security solution.

Focus on What Matters

- ▶ Centralize your video and access control monitoring with our seamless Valerus VMS integration
- ▶ Globally link action triggers with Action Control Engine Setup privileges in less than a minute with customizable user templates
- ▶ Customizable notifications so operators only see the most critical information
- ▶ Color-coded dashboards display intel on system health and status to quickly pinpoint potential concerns
- ▶ Monitor your access control remotely with our mobile app

Reduce Maintenance Time and Costs

- ▶ Maintain software centrally with a thin-client topology
- ▶ Supports all major web browsers
- ▶ Proactively receive warnings for system warnings, such as high database usage

Integrate Into Your Existing System

- ▶ Integrate with HID EasyLobby® for efficient visitor management
- ▶ Integrate with major third-party video management systems through our Open Platform

Scale With Your Operation

- ▶ Manage unlimited sites across multiple time zones
- ▶ Unlimited doors, users and time zones
- ▶ Configure new sites in a fraction of the time with our Data Migrator

Secure Your Data

- ▶ Supports OSDP and MIFARE
- ▶ Advanced SSL encryption ensures system security; 256 bit AES encryption option
- ▶ Configure new sites in a fraction of the time with our Data Migrator

Key Features

Integration with VMS

VAX integrates with Vicon Valerus™ to centralize monitoring of access control and video. Users can override doors, view live access events, create VAX alarms, control VAX I/Os, and trigger VAX action plans directly within the Valerus interface. VAX can also integrate with ViconNet® VMS, Milestone®, Digital Watchdog® and Exacq® VMS to associate and see video in the VAX interface for immediate visual verification.

Powerful Action Plans

An event, or series of events, can be triggered when a specific condition is met. These can be triggered in a number of ways—including automatically—depending on your preference and the level of urgency. And they can also be triggered via the Valerus UI.

Data Migrator

Easily duplicate specific site data from one location to another, making expansion or moving systems quick and simple and allowing focus to remain on mission-critical details during any transition.

Vicon Pass Temporary Visitor Access

The Vicon-Pass application allows visitors to receive a web link that will grant them access to a specific door. Visitors will receive a text or email containing a one-time link they can click to unlock.

Other Innovative Features

Credential validation can be based on time of day, day of week, holiday scheduling, door mode and any customized scheduling, as well as credential combinations.

Anti-passback prevents any credential (card, fob, PIN) from being used twice to gain access without exiting first.

Built-in ID badging feature lets you create custom ID badges directly within the VAX application.

Real-time push notifications to never miss a critical event, even when multi-tasking.

Advanced Interactive Mapping

An interactive map feature is provided that can scale to any need, whether a single map or multi-building or multi-floor solution is required. They offer easy navigation between buildings, floors and areas, with real-time status and live viewing available with a click.

Support for Multi-Door Controllers

VAX supports PRS (Panel Retrofit/Room Style) master controllers that allow multiple doors to be managed through a single IP address. The master controller supports live firmware updates and allows custom actions to be executed and schedules to be defined at the panel level.

Status and Health Dashboard

VAX contains an intuitive, color-coded dashboard that displays intel on system health and status, so you can quickly pinpoint concerns that may need further attention. The drag-and-drop widget interface lets you customize it according to your preference.

Unmanaged and Monitored Doors

Doors that are not controlled by VAX but do have a door contact can be monitored using the input from the contact to determine its status. An Unmanaged Door has all the features of traditional Managed Doors except it has no reader.

Customized alarm notifications help operators focus on critical notices and improve reaction times.

OSDP support for end-to-end encryption between readers and panels.

Mobile apps allow you to monitor your access control system on-the-go.

HID EasyLobby® integration grants visitor access via a visitor card assigned through EasyLobby.

New integrations include Schlage Wireless Readers and DSC Alarm Panels.

System Requirements

Model	Minimum PC Specifications
Operating System:	Windows 10 or Windows Server 2016 is recommended for optimal performance
CPU:	Intel® Core™ i5 processor or better
Memory:	4 GB RAM or greater
DVD Drive:	Optional
Hard Disk Drives:	250 GB or greater
Network Interface:	100/1000 Base T Ethernet interface on main board

Ordering Information

Model Number	License Type	No. of Doors/Cameras	No. of Partitions	No. of IO	No. of Elevator Cabs	Unmanaged/ Monitored Doors*	LDAP Support
VAX Licenses							
VAX-SW40-1YR	1 Year	40/40	1	Unlimited	No	No	No
VAX-SW40-3YR	3 Year	40/40	1	Unlimited	No	No	No
VAX-SW80-1YR	1 Year	80/80	5	Unlimited	Unlimited	Yes	Yes
VAX-SW80-3YR	3 Year	80/80	5	Unlimited	Unlimited	Yes	Yes
VAX-SW120-1YR	1 Year	120/120	20	Unlimited	Unlimited	Yes	Yes
VAX-SW120-3YR	3 Year	120/120	20	Unlimited	Unlimited	Yes	Yes
VAX-SW240-1YR	1 Year	240/240	40	Unlimited	Unlimited	Yes	Yes
VAX-SW240-3YR	3 Year	240/240	40	Unlimited	Unlimited	Yes	Yes
VAX-SWU-1YR	1 Year	Unlimited/Unlimited	Unlimited	Unlimited	Unlimited	Yes	Yes
VAX-SWU-3YR	3 Year	Unlimited/Unlimited	Unlimited	Unlimited	Unlimited	Yes	Yes
VAX-SCHLAGE	Perpetual License; supports on Schlage Wireless Lock (VAX 3.1 software minimum)						
VAX-ENGAGE-GATEWAY	Allegion IP Gateway; capable of controlling up to 10 ENGAGE Series LE and NDE wireless locksets. GATEWAY is added in VAX and requires VAX-SCHLAGE license per 1 LE or NDE wireless lockset.						

*A Monitored Door is a door that is not controlled by the access control system but does have a door contact. The input from the door contact is used to determine if the door is open or closed. An Unmanaged Door has all the features of a Managed Door except there is no reader.

Dedicated VAX Servers

Vicon also offers powerful, dedicated Vicon Access Control Servers available in micro desktop (VEVA-MC00N-00) and 1U rack mount (VEAA-1U00N0-00) form factors.

These units are engineered specifically for VAX to ensure you have the best hardware for your access control solution.



Dimension Drawings

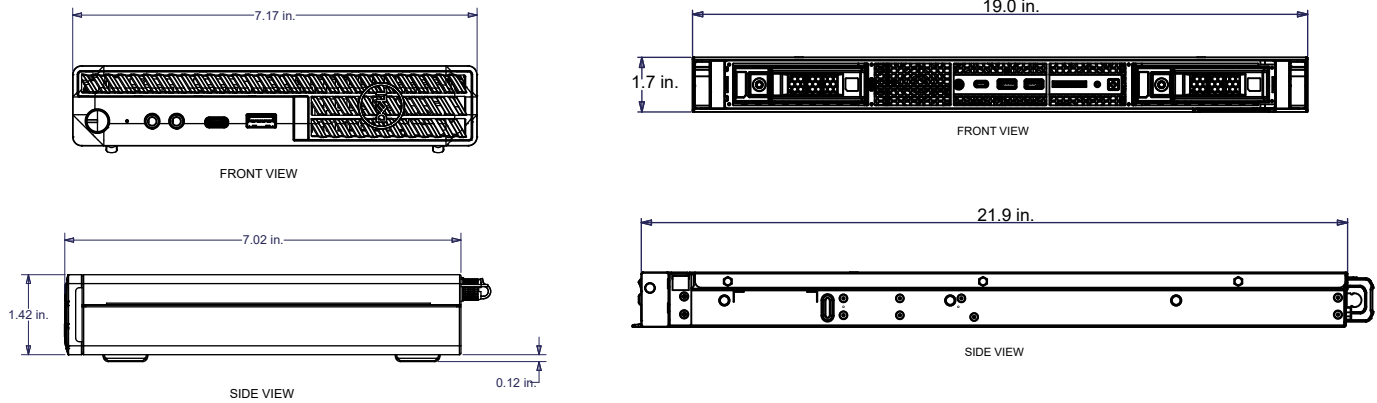

Server Specifications

Model	Micro VEVA-MC00N0-00	Rack-Mount VEAA-1U00N0-00
Operating System:	Microsoft® Windows® 10/11 Enterprise IoT	Microsoft® Windows® 11 Enterprise IoT; Windows Server
CPU/RAM:	Intel® Core® i5 14th Gen, 16 GB DDR4	Xeon®; 16 GB DDR4
OS Drive:	1x 256 GB M.2 SSD	480 GB SSD
Additional Ports:	Intel HD (HDMI+DP)(Video); 2x USB 3.2 Gen 1; 2x USB 2.0; 1x Kensington Lock; 1x USB 3.2 + 1x USB 3.2 Type-C; 1x Universal Audio Port	Rear: 1x USB 2.0; 1x USB 3.2; 1x Serial 1x Front: 1x USB; 1x Micro USB for iDRAC; status LEDs; Power Button
Networking:	1x 1GbE RJ-45	2x 1 GbE; 1x RJ-45 iDRAC; 2x 10 GbE
Certifications:	NDAA-compliant	
Electrical		
Power Supply:	1x 90 W external PSU	600 W, dual redundant
Typical Power Consumption:	60 W (200 BTU)	250 W (850 BTU)
Max. Power Consumption:	90 W (300 BTU)	300 W (1000 BTU).
Power Connector:	Standard 3-conductor female socket	
Mechanical		
Application:	Indoor	
Mounting:	Micro form factor desktop	Rack-mount, 1 RU height
Dimensions (HxWxD):	7.17 in. (182 mm) x 1.42 in.(36 mm) x 7.02 in. (178.6 mm)	1.7 in. (42.8 mm) x 19 in. (483 mm) x 21.9 in. (556.2 mm) (with bezel)
Weight:	2.95 lb (1.34 kg).	29.17 lb (13.23 kg)
Construction:	Steel and plastic	
Environmental		
Operating Conditions:	Temp: 50° to 95°F (10° to 35°C). Humidity: 20 to 80% relative, non-condensing.	50° to 95° F (10° to 35° C). Humidity: 10 to 85% relative, non-condensing
Country of Origin:	Mexico	
Warranty:	5 years parts and labor	

Server Ordering Information

Model Number	Description
VAX Servers	
VEVA-MC00N0-00	VAX Server; for customized preinstallation of selected VAX software license; micro desktop model
VEAA-1U00N0-00	Valerus Application/VAX Server; for customized preinstallation of selected VAX software license; 1U rack-mount model

Data Sheet Number: V274-13-07

Specifications subject to change without notice.

Vicon, VAX, Valerus, ViconNet and their logos are registered trademarks or trademarks of Vicon Industries Inc.

Copyright © 2025 Vicon Industries Inc. All rights reserved.

Microsoft and Windows are registered trademarks of Microsoft Corporation.

Intel and Core are registered trademarks or trademarks of Intel Corporation.